

2/2-Way, NPT 1/2 – NPT 2



Advantages/Benefits

- ▶ Zero differential pressure
- ▶ Body material: brass
- ▶ Fluid temperature up to 356°F
- ▶ High reliability
- ▶ Erosion resistant
- ▶ Approvals



listed up to 1"

Design/Function

Type 407 is a normally-closed servo-assisted on-off solenoid valve with a coupled armature/servo piston (circuit function A).

When de-energized, the spring acts on the armature to close the pilot channel in the piston.

When energized, the armature lifts to open the pilot channel to relieve the pressure. Even if there is no pressure differential, the armature lifts the coupled piston to open the valve.

Applications

- Fluids at higher temperatures, e.g. hot air, steam
- Vacuum
- Autoclaves (vacuum side)
- Relief of steam systems
- All industrial areas

Burkert Contromatic USA
2602 McGaw Avenue
Irvine, CA 92614
Tel. 949.223.3100
Fax 949.223.3198
www.burkert-usa.com

Burkert Contromatic Inc.
760 Pacific Road, Unit 3
Oakville, Ontario, Canada L6L 6M5
Tel. 905.847.5566
Fax 905.847.9006
www.burkert.ca

Technical Data

Circuit Function

A 2/2-way valve, normally closed, with 2-way pilot control

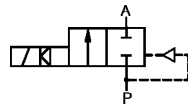

Body Material

Threaded: Body of brass, seat 1.4303
 Internal parts: Solenoid system 1.4105
 Servo piston of brass
 Cover: Brass

Specifications

Orifice DN [mm]	Cv-Value Water [GPM]	Cv-Value Air [SCFM]	Pressure Range [PSI]	Weight Thread [lbs]
13	4.3	140	0-140	2.2
20	5.8	190	0-140	3.1
25	11.7	380	0-140	4.2
32	19.0	600	0-140	7.0
40	19.0	600	0-140	8.0
50	42.0	1400	0-140	17.2

The pressure range is also valid for technical vacuum.
 All pressures quoted are gauge pressures with respect to the prevailing atmospheric pressure.

Operating Data (Valve)

Seal Materials/Fluids Handled/Temp.- Range

PTFE Neutral fluids, e.g. hot water, steam
 0°F to 356°F

For more detailed information, please refer to resistance chart (Leaflet-No. 1896009).

Max. ambient temperature	131°F		
Max. viscosity	21 cSt		
Response times DN	opening	closing	
	[ms]	[ms]	[ms]
13-25	0.1 - 0.2	0.3 - 0.5	
32-50	0.2 - 1.2	1.0 - 3.0	

Measured at outlet port A from switching on until pressure rise to 90% / pressure drops to 10% at a working pressure of 21 PSI.

Port connection NPT 1/2, 3/4, 1, 1 1/4, 1 1/2, 2

Operating Data (Actuator)

Operating voltages	AC 24, 10, 240/60 Hz AC/DC 110, 240/UC (universal current)
Voltage tolerance	±10%
Power consumption	AC 100 VA (inrush) 35 VA/16 W (hold)
Duty cycle	100% continuously rated
Cycling rate	10-60 c.p.m.
Coil Insulation Class	Class H
Rating	NEMA 4 (IP65) with cable plug

Installation / Accessories

Installation	as required, but preferably with solenoid system upright.
Electrical connection	UL listed: Conduit plug Non UL: Spade connects Cable plug DIN 43650, form A (sold separately) Universal current; Cable plug with integrated single phase bridge rectifier.

Dimensions in mm

Ported Version

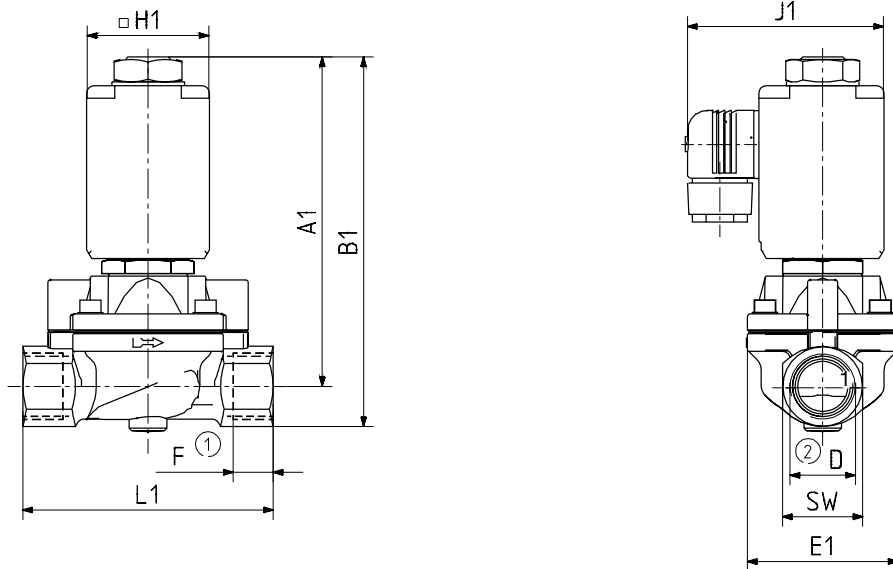

Orifice [mm]	Ported Version								
	A1	B1	D	F	E1	L1	SW	J1	H1
13	113	127	NPT 1/2	14	40	65	27	73.0	40
20	131	147	NPT 3/4	16	60	100	32	80.5	49
25	136,5	157	NPT 1	18	70	115	41	80.5	49
32	161	186	NPT 1 1/4	20	85	126	50	80.5	49
40	165	195	NPT 1 1/2	22	85	126	60	80.5	49
50	225	260	NPT 2	24	115	164	70	104.5	72

Solenoid Valve for Steam and Media at High Temperatures up to 356°F

Type 407

Ordering Chart (Other Versions on Request)

Circuit Function	Orifice DN [mm]	Flow Rate Water Cv-Value [GPM]	Air CV [SCFM]	Port Connection [NPT]	Pressure Range [PSI]	Body Material	Seal Material	Weight [lbs]	Voltage/Frequency [V/Hz]	Order-No.
A	13.0	4.3	1400	1/2	0-140	Brass	PTFE	2.2	24/60	453 046 Z
									120/60	453 045 Y
									240/60	US01471
	20.0	5.8	190	3/4	0-140	Brass	PTFE	3.1	24/60	453 048 B
									120/60	453 047 S
									240/60	US00650
	25.0	11.7	380	1	0-140	Brass	PTFE	4.2	24/60	453 050 H
									110/60	453 049 C
									240/60	453 194 K
	32.0	19.0	600	1 1/4	0-140	Brass	PTFE	7.0	24/60	US01391
									110/60	453 902 Z
	40.0	19.0	600	1 1/2	0-140	Brass	PTFE	8.0	24/60	US00563
									120/60	453 903 S
									240/60	456 476 Y
	50.0	42.0	1400	2	0-140	Brass	PTFE	17.2	110/UC ¹⁾	454 357 E
									240/UC ¹⁾	456 289 D

¹⁾ UC (universal current), cable plug with integrated single-phase bridge rectifier.