

Catalog 4182/USA
April 2003



Table of Contents

Technical Information	3
Manual Valves	
MV-1 Manual PTFE Stop Cock Valve	4
MV-4 Manual PTFE Needle Valve	6
MV-6 Manual PTFE Ball Valve	8
MV-7 Manual PTFE Tapered Plug Valve	10
MV-8 Manual PTFE Sampling Valve	12
MV-10 1/4" Manual PFA 2 Way Valve	14
MV-10 1/4" Manual PFA 3 Way Valve	16
MV-11 1/2" Manual PFA 2 Way Valve	18
MV-11 1/2" Manual PFA 3 Way Valve	20
MV-11 1/2" Manual PFA 2 Way Adjustable Valve	22
MV-12 1" Manual PFA 2 Way Valve	24
MV-13 Manual PFA Needle Valve	26
MV-14 Manual PFA Stop Cock Valve	28
Pneumatic Valves	
PV-1 Miniature Pneumatic PTFE Valve	30
PV-10 1/4" Pneumatic PFA 2 Way Valve	32
PV-10 1/4" Pneumatic PFA 3 Way Valve	34
PV-11 1/2" Pneumatic PFA 2 Way Valve	36
PV-11 1/2" Pneumatic PFA 3 Way Valve	38
PV-11 1/2" Pneumatic PFA 2 Way Adj. Bypass Valve	40
PV-12 1" Pneumatic PFA 2 Way Valve	42
PV-13 1/4" Pneumatic PTFE CMP Valve	44
PV-14 3/8" Pneumatic PTFE Valve	46
Other Valves	
CV-1 1/4" - 1" PTFE Check Valve	48
RV 1/4" PTFE Relief Valve	50
Offer of Sale	54

WARNING

FAILURE OR IMPROPER SELECTION OR IMPROPER USE OF THE PRODUCTS AND/OR SYSTEMS DESCRIBED HEREIN OR RELATED ITEMS CAN CAUSE DEATH, PERSONAL INJURY AND PROPERTY DAMAGE.

This document and other information from Parker Hannifin Corporation, its subsidiaries and authorized distributors provide product and/or system options for further investigation by users having technical expertise. It is important that you analyze all aspects of your application and review the information concerning the product or system in the current product catalog. Due to the variety of operating conditions and applications for these products or systems, the user, through its own analysis and testing, is solely responsible for making the final selection of the products and systems and assuring that all performance, safety and warning requirements of the application are met.

The products described herein, including without limitation, product features, specifications, designs, availability and pricing, are subject to change by Parker Hannifin Corporation and its subsidiaries at any time without notice.

© Copyright 2003, Parker Hannifin Corporation, All Rights Reserved

Overview

Partek/Atlantic produces products that are made from only the finest Fluoropolymers available. These Fluoropolymers are resistant to numerous chemicals and solvents. This information provides only a brief technical overview. For more comprehensive technical and chemical compatibility information, please ask for Technical Bulletin 0002-T1/USA.

Fluorinated Polymers

Chemical Properties

- Resistivity to corrosive agents
- Non-solubility
- Long term weatherability
- Non-adhesiveness
- Nonflammability

Electrical Properties

- Low dielectric constant
- Low dissipation factor
- High arc resistance
- High surface resistance
- High volume resistivity

Mechanical Properties

- Flexibility at low temperatures
- Low coefficient of friction
- Stability at high temperatures

PTFE is a fluorocarbon resin that is isostatically compression molded into various shapes and configurations. It is chemically resistant to all chemicals and solvents with the exception of some molten alkali metals, molten sodium hydroxide, elemental fluorine and certain fluorinating agents. At Partek we use PTFE for machining the bodies and components of various valves and manifolds. It offers chemical resistance and stability at high temperatures.

Modified PTFE material is used primarily for diaphragms and bellows in our products. This material has the same processing and chemically resistant characteristics as the standard product but offers superior cycle life and integrity in diaphragm products.

PFA is a copolymer of tetrafluoroethylene and perfluoroalkyl vinyl ether. The resultant polymer contains the carbon-fluorine backbone chain typical of PTFE, but unlike PTFE, does not require special fabricating techniques. PFA pellets have good melt flow characteristics that allow for processing via extrusion, compression, blow, transfer and injection molding methods. It has outstanding chemical and solvent resistant characteristics over a temperature range even greater than PTFE. PFA is offered in various grades of purity and cleanliness making it the material of choice for the semiconductor market.

C_V and K_V Formulas

$$Q = C_V \sqrt{\frac{\Delta P}{SG}}$$

Q = Flow (GPM)
 ΔP = Pressure Drop (PSIG)
 SG = Specific Gravity

$$Q = K_V \sqrt{\frac{\Delta P}{Y}}$$

Q = Flow (LPM)
 ΔP = Pressure Drop (BAR)
 Y = Specific Gravity (kg/cm³)

$$1 K_V = 14.26 C_V$$

“C_V” flow factor is the number of gallons of fluid that pass through a given orifice area in one minute, at a pressure drop of 1 PSIG.

“K_V” flow factor is the number of liters of fluid that pass through a given orifice area in one minute, at a pressure drop of 1 bar.

PERCENT OF RATED PRESSURE VS. TEMPERATURE

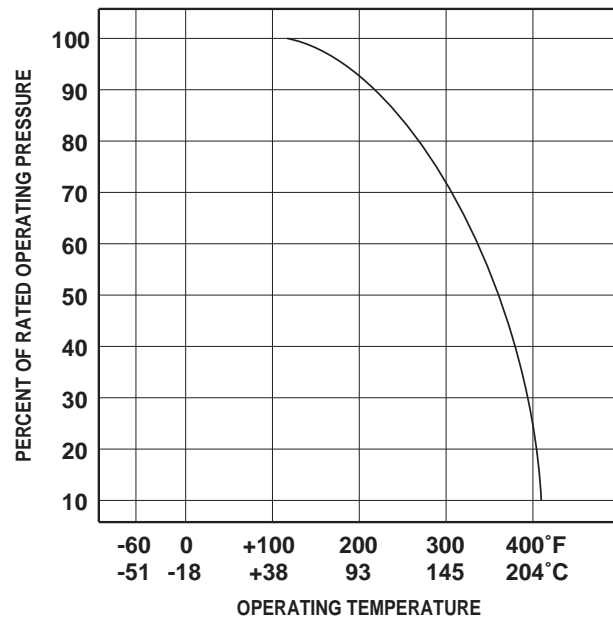

For operation at temperatures above ambient conditions, please refer to the chart above for reduced pressure ratings.

MV-1 Manual Stop Cock Valve

Product Overview

The MV-1 Stop Cock Valve is designed for use in high purity semiconductor fluid applications, and is also ideally suited for ultra-pure water and aggressive chemicals. A precision-machined PTFE body with a straight through flowpath is combined with a PTFE full flow orifice stem for maximum flow, minimum pressure drop and 1/4" turn operation. Two and three way configurations, both "L" and "T" styles, are offered for inline and panel mounted applications.



Features

Full flow orifice.

The precision machined stem and body provide tight shut off and 1/4 turn operation.

"L" and "T" style 3-way configurations available.

Parofluor O-Ring stem seals.

Benefits

Maximum flow at the desired size.

Minimum pressure drop. High cycle life.

Eliminates valve redundancy.

Positive body to stem seal.

Specifications

Materials of Construction:

Wetted Surfaces - PTFE, Parker Parofluor™

Non Wetted Surfaces - HDPE, PFA, PVC, PVDF, Titanate.

Pressure Ranges:

0 to 60 PSIG (4.1 bar)

Pressure ranges above are for operation at ambient temperature. For use at higher temperatures consult Pressure/Temperature chart on page 3.

Temperature Ranges:

-60° - 212° F (-51° - 100° C) Ambient

-60° - 400° F (-51° - 204° C) Fluid

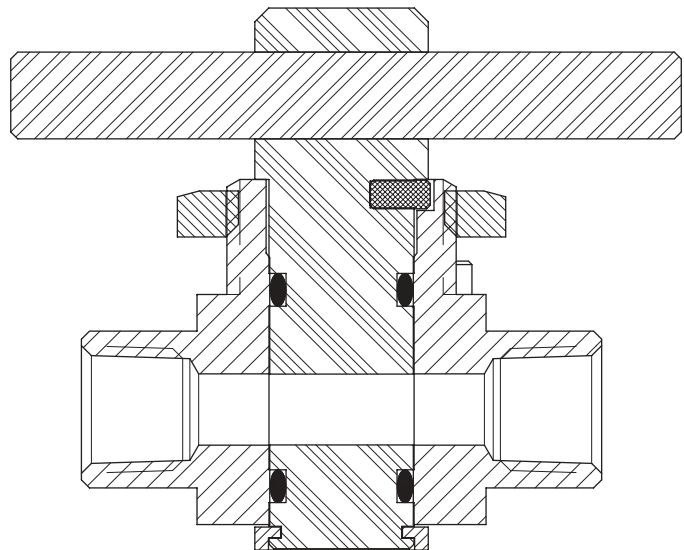

MV-1 Manual Stop Cock Valve

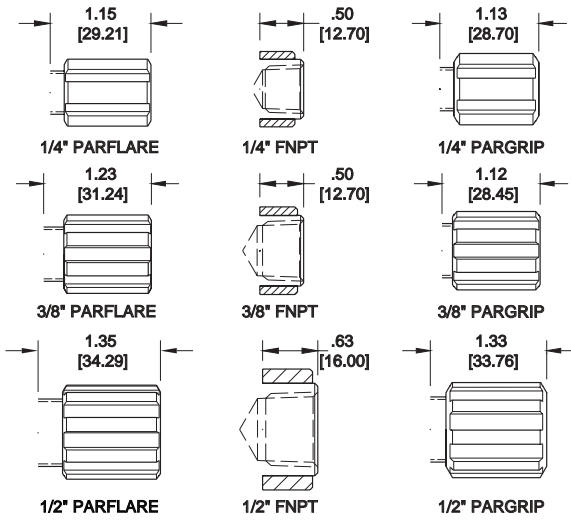
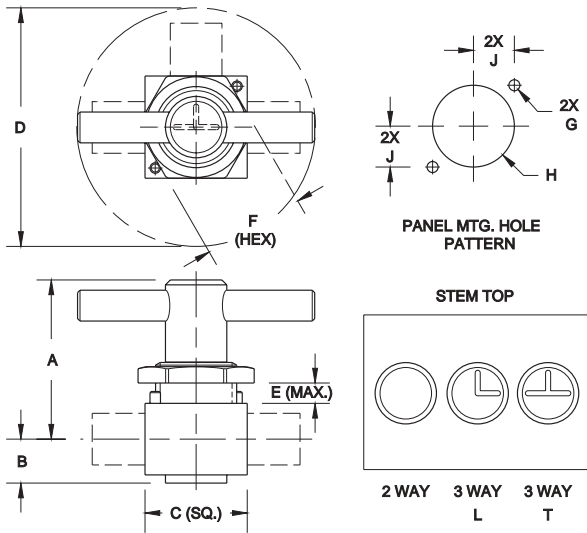

DIMENSIONS (in.)

	A	B	C	D	E	F	G	H	J
MV-1-1414	1.78	.61	1.25	Ø 2.92	.25	1.31	Ø .14	Ø 1.00	.50
MV-1-14X4	1.78	.61	1.25	Ø 2.92	.25	1.31	Ø .14	Ø 1.00	.50
MV-1-2314	1.78	.61	1.25	Ø 2.92	.25	1.31	Ø .14	Ø 1.00	.50
MV-1-23X4	1.78	.61	1.25	Ø 2.92	.25	1.31	Ø .14	Ø 1.00	.50
MV-1-6214	1.78	.61	1.25	Ø 2.92	.25	1.31	Ø .14	Ø 1.00	.50
MV-1-62X4	1.78	.61	1.25	Ø 2.92	.25	1.31	Ø .14	Ø 1.00	.50
MV-1-1616	2.24	.74	1.50	Ø 2.92	.50	1.75	Ø .20	Ø 1.44	.60
MV-1-16X6	2.24	.74	1.50	Ø 2.92	.50	1.75	Ø .20	Ø 1.44	.60
MV-1-2416	1.78	.61	1.25	Ø 2.92	.25	1.31	Ø .14	Ø 1.00	.50
MV-1-24X6	2.24	.74	1.50	Ø 2.92	.50	1.75	Ø .20	Ø 1.44	.60
MV-1-6416	1.78	.61	1.25	Ø 2.92	.25	1.31	Ø .14	Ø 1.00	.50
MV-1-64X6	2.24	.74	1.50	Ø 2.92	.50	1.75	Ø .20	Ø 1.44	.60
MV-1-1818	2.24	.74	1.50	Ø 2.92	.50	1.75	Ø .20	Ø 1.44	.60
MV-1-18X8	2.24	.74	1.50	Ø 2.92	.50	1.75	Ø .20	Ø 1.44	.60
MV-1-2618	2.24	.74	1.50	Ø 2.92	.50	1.75	Ø .20	Ø 1.44	.60
MV-1-26X8	2.24	.74	1.50	Ø 2.92	.50	1.75	Ø .20	Ø 1.44	.60
MV-1-6618	2.24	.74	1.50	Ø 2.92	.50	1.75	Ø .20	Ø 1.44	.60
MV-1-66X8	2.24	.74	1.50	Ø 2.92	.50	1.75	Ø .20	Ø 1.44	.60

DIMENSIONS (mm.)

	A	B	C	D	E	F	G	H	J
45.21	15.49	31.75	Ø 74.17	6.35	33.27	Ø 3.56	Ø 25.40	12.70	
45.21	15.49	31.75	Ø 74.17	6.35	33.27	Ø 3.56	Ø 25.40	12.70	
45.21	15.49	31.75	Ø 74.17	6.35	33.27	Ø 3.56	Ø 25.40	12.70	
45.21	15.49	31.75	Ø 74.17	6.35	33.27	Ø 3.56	Ø 25.40	12.70	
45.21	15.49	31.75	Ø 74.17	6.35	33.27	Ø 3.56	Ø 25.40	12.70	
45.21	15.49	31.75	Ø 74.17	6.35	33.27	Ø 3.56	Ø 25.40	12.70	
56.90	18.80	38.10	Ø 74.17	12.70	44.45	Ø 5.08	Ø 36.58	15.24	
56.90	18.80	38.10	Ø 74.17	12.70	44.45	Ø 5.08	Ø 36.58	15.24	
45.21	15.49	31.75	Ø 74.17	6.35	33.27	Ø 3.56	Ø 25.40	12.70	
56.90	18.80	38.10	Ø 74.17	12.70	44.45	Ø 5.08	Ø 36.58	15.24	
45.21	15.49	31.75	Ø 74.17	6.35	33.27	Ø 3.56	Ø 25.40	12.70	
56.90	18.80	38.10	Ø 74.17	12.70	44.45	Ø 5.08	Ø 36.58	15.24	
45.21	15.49	31.75	Ø 74.17	6.35	33.27	Ø 3.56	Ø 25.40	12.70	
56.90	18.80	38.10	Ø 74.17	12.70	44.45	Ø 5.08	Ø 36.58	15.24	
56.90	18.80	38.10	Ø 74.17	12.70	44.45	Ø 5.08	Ø 36.58	15.24	
56.90	18.80	38.10	Ø 74.17	12.70	44.45	Ø 5.08	Ø 36.58	15.24	
56.90	18.80	38.10	Ø 74.17	12.70	44.45	Ø 5.08	Ø 36.58	15.24	
56.90	18.80	38.10	Ø 74.17	12.70	44.45	Ø 5.08	Ø 36.58	15.24	
56.90	18.80	38.10	Ø 74.17	12.70	44.45	Ø 5.08	Ø 36.58	15.24	

Model Number	Cv	Kv	Orifice Size	Flow Config.	Port Config.
MV-1-1414	1.95	27.8	.250	2 WAY	1/4" FNPT
MV-1-2314	.75	10.7	.188	"	1/4" Pargrip
MV-1-6214	.36	5.1	.125	"	1/4" Parflare
MV-1-1616	3.00	42.8	.375	"	3/8" FNPT
MV-1-2416	1.95	27.8	.250	"	3/8" Pargrip
MV-1-6416	1.95	27.8	.250	"	3/8" Parflare
MV-1-1818	6.55	93.4	.438	"	1/2" FNPT
MV-1-2618	3.00	42.8	.375	"	1/2" Pargrip
MV-1-6618	3.00	42.8	.375	"	1/2" Parflare

Model Number	Cv	Kv	Orifice Size	Flow Config.	Port Config.
MV-1-14X4	1.95	27.8	.250	3 WAY*	1/4" FNPT
MV-1-23X4	.75	10.7	.188	"	1/4" Pargrip
MV-1-62X4	.36	5.1	.125	"	1/4" Parflare
MV-1-16X6	3.00	42.8	.375	"	3/8" FNPT
MV-1-24X6	1.95	27.8	.250	"	3/8" Pargrip
MV-1-64X6	1.95	27.8	.250	"	3/8" Parflare
MV-1-18X8	6.55	93.4	.438	"	1/2" FNPT
MV-1-26X8	2.50	35.7	.313	"	1/2" Pargrip
MV-1-66X8	2.50	35.7	.313	"	1/2" Parflare

* For 3 Way L change X to "2" (i.e. MV-1-1424) and for 3 Way T change X to "3" (i.e. MV-1-1434).

PRESSURE DROP VS. FLOW RATE

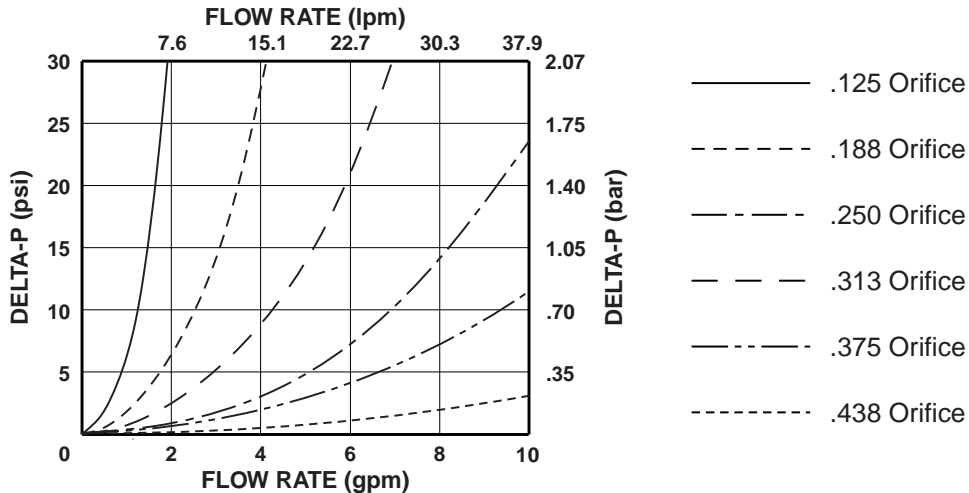

MV-4 Manual Needle Valve

Product Overview

The MV-4 Needle Valve is designed for high purity or aggressive chemical and gas applications. The design utilizes a machined high purity PTFE body and stem as the only wetted components. The stem sealing area is precision machined for smooth, consistent flow. The PTFE ferrule assures a leak tight seal between the stem and body. The unique fluted needle design provides precise, repeatable flow control. The MV-4 is available in a straight through configuration with several orifice sizes and numerous end connections.



Features

Tapered groove needle design

PVDF trim option

Numerous end connections available including Parflare.

Benefits

Allows for precise, repeatable linear flow control.

Reduces effects of corrosive environment.

Reduces connections, mounting space and overall cost.

Ideal for quick shut-off in contamination-free applications.

Specifications

Materials of Construction:

Wetted Surfaces - PTFE

Non Wetted Surfaces - Anodized Aluminum, ABS, 18-8 SS.

Pressure Ranges:

25" HG vacuum (846 mbar) to 120 PSIG (8.3 bar)

Pressure ranges above are for operation at ambient temperature. For use at higher temperatures consult Pressure/Temperature chart on page 3.

Temperature Ranges:

0° - 150° F (-17° - 66° C) Ambient

0° - 266° F (-17° - 130° C) Fluid

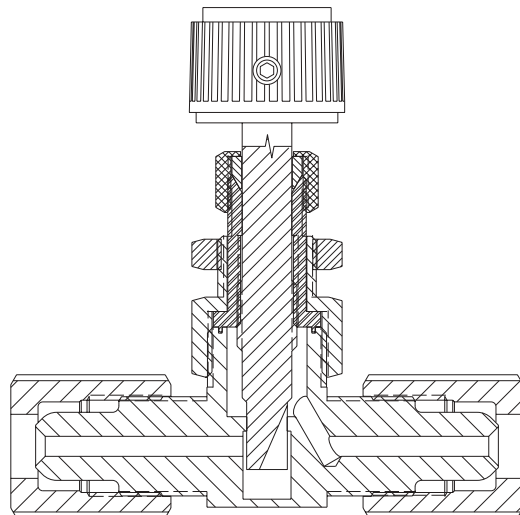

MV-4 Manual Needle Valve



BRACKETED DIMENSIONS
ARE IN mm.

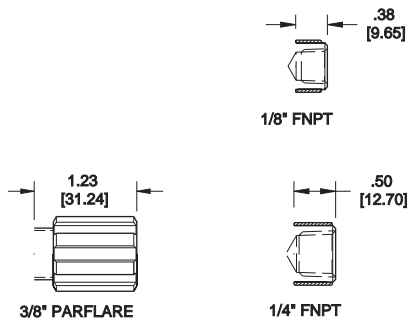
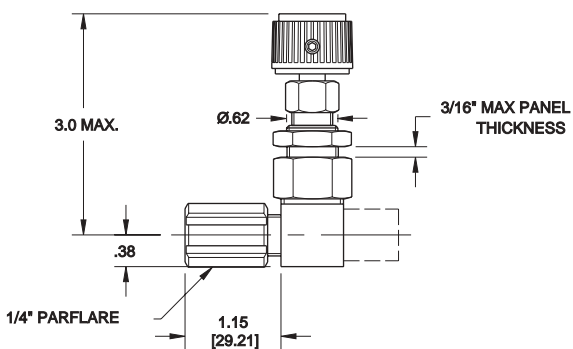

Model Number	C _v	K _v	Orifice Size	Flow Config.	Port Configuration
MV-4-1014	.02	.21	.031	ON/OFF	1/4" FNPT
MV-4-1114	.08	1.10	.063	*	1/4" FNPT
MV-4-1212	.21	2.99	.125	*	1/8" FNPT

Model Number	C _v	K _v	Orifice Size	Flow Config.	Port Configuration
MV-4-1214	.21	2.99	.125	ON/OFF	1/4" FNPT
MV-4-6214	.21	2.99	.125	*	1/4" Parflare
MV-4-6216	.21	2.99	.125	*	3/8" Parflare

Above Parflare model numbers are supplied with PVDF nuts. For PFA nuts add -T to model number. For high temperature nut assemblies, add -HT. Consult factory for delivery and pricing. Please consult factory for other available configurations, PVDF trim options and custom assemblies.

C_v / K_v vs. Turns

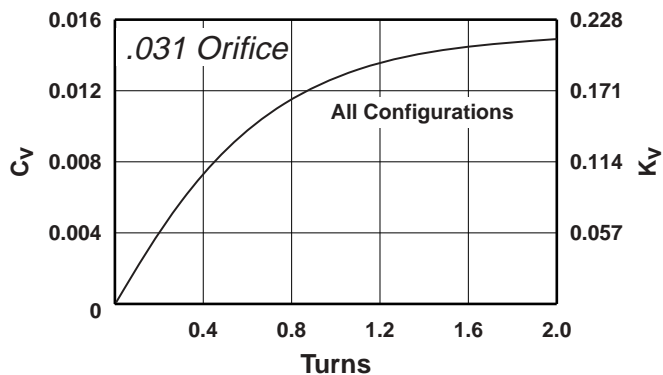

C_v / K_v vs. Turns

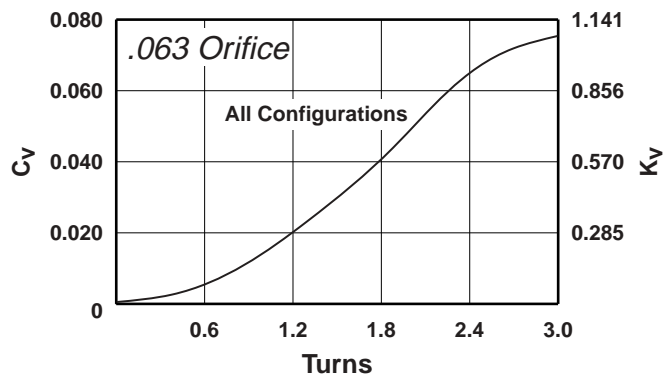

C_v / K_v vs. Turns

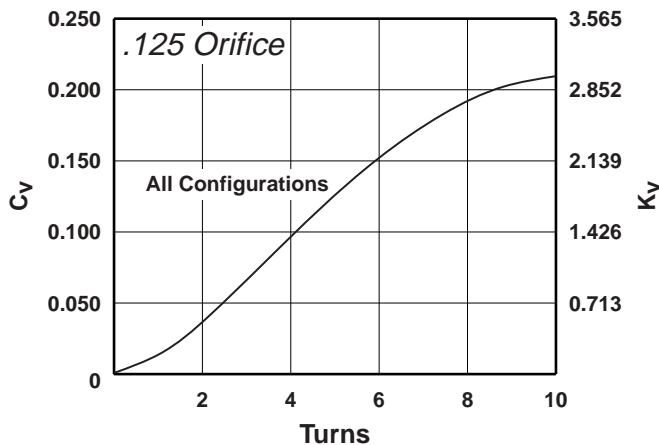

MV-6 Manual Ball Valve

Product Overview

The MV-6 Ball Valves are designed for use in high purity semiconductor applications, and are also ideally suited for use in ultra-pure water and aggressive chemicals. All sizes have wetted parts made entirely of PTFE. All valves are designed full port for minimal flow restrictions and are operated 1/4 turn with minimal torque.



Features

Floating ball design without o-rings ensures bubble tight sealing at high pressure.

Full port design; 1/4 turn operation with low torque tee handle.

Panel mounting is an option on all sizes.

Benefits

Bidirectional flow to 120 psi liquid or gas; High cycle life.

Ideal for quick shut-off in contamination-free applications.

Ideal for process instrumentation applications.

Specifications

Materials of Construction:

Wetted Surfaces - PTFE

Non Wetted Surfaces - HDPE, PVDF and PVC.

Pressure Ranges:

25" HG vacuum (846 mbar) to 120 PSIG (8.3 bar)

Pressure ranges above are for operation at ambient temperature. For use at higher temperatures consult Pressure/Temperature chart on page 3.

Temperature Ranges:

-60° - 176° F (-51° - 80° C) Ambient

-60° - 400° F (-51° - 204° C) Fluid

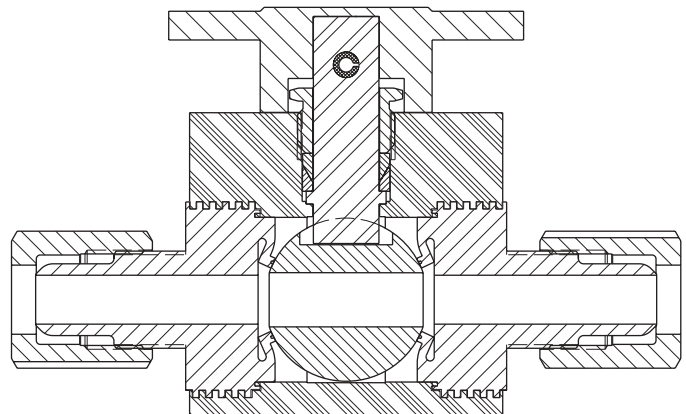

MV-6 Manual Ball Valve

BRACKETED DIMENSIONS ARE IN mm.

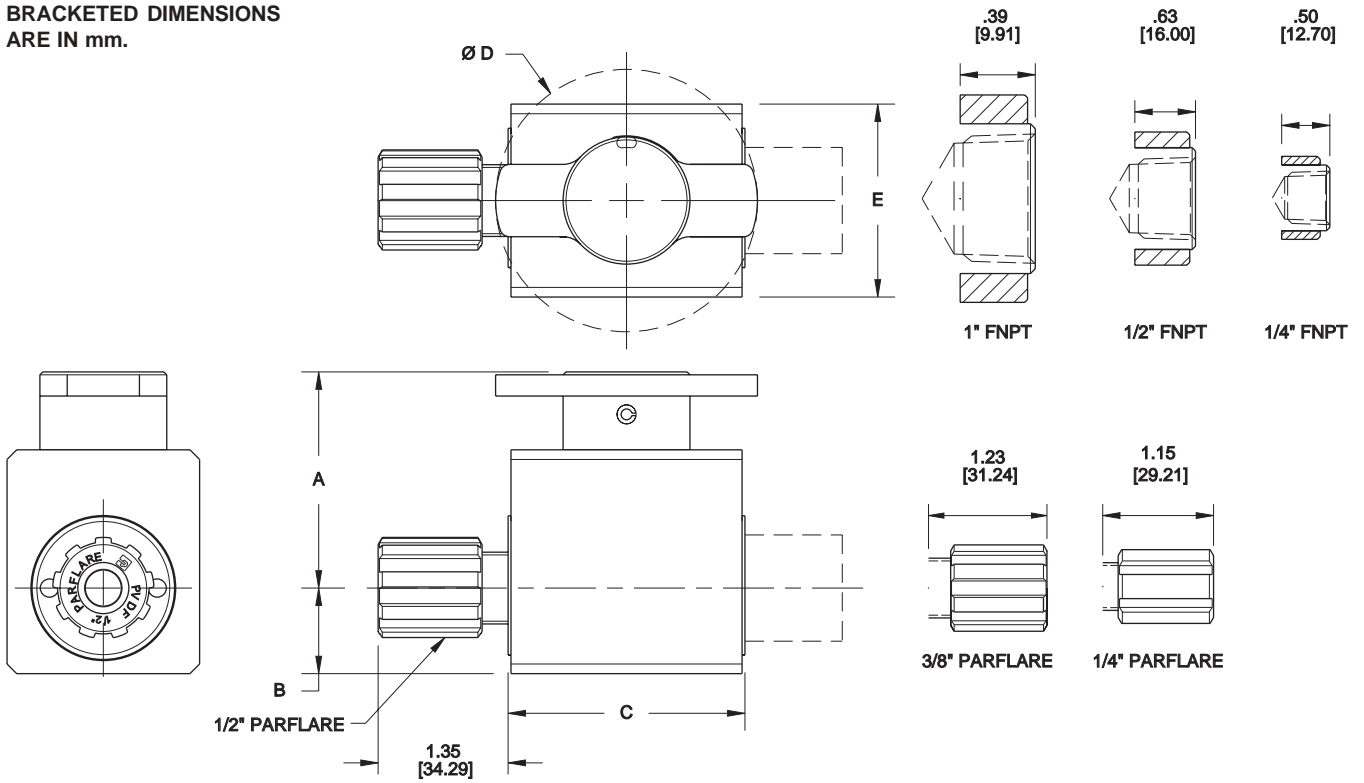

DIMENSIONS (in.)						DIMENSIONS (mm.)					
	A	B	C	D	E	A	B	C	D	E	
MV-6-1414-0	1.73	.66	1.91	Ø 1.98	1.31	43.94	16.76	48.51	Ø 50.29	33.27	
MV-6-1818-0	2.24	.89	2.46	Ø 2.72	2.00	56.89	22.60	62.48	Ø 69.08	50.80	
MV-6-116116-0	3.18	1.39	3.44	Ø 4.40	2.53	80.77	35.30	87.37	Ø 111.76	64.26	
MV-6-6214-0	1.73	.66	1.91	Ø 1.98	1.31	43.94	16.76	48.51	Ø 50.29	33.27	
MV-6-6416-0	2.24	.89	2.46	Ø 2.72	2.00	56.89	22.60	62.48	Ø 69.08	50.80	
MV-6-6618-0	2.24	.89	2.46	Ø 2.72	2.00	56.89	22.60	62.48	Ø 69.08	50.80	

Model Number	Cv	Kv	Flow Config.	Port Configuration
MV-6-1414-0	1.88	26.81	ON/OFF	1/4" FNPT
MV-6-1818-0	6.59	93.97	"	1/2" FNPT
MV-6-116116-0	28.06	400.14	"	1" FNPT

Model Number	Cv	Kv	Flow Config.	Port Configuration
MV-6-6214-0	1.01	14.40	ON/OFF	1/4" Parflare
MV-6-6416-0	1.88	26.81	"	3/8" Parflare
MV-6-6618-0	3.15	44.92	"	1/2" Parflare

PRESSURE DROP VS. FLOW RATE

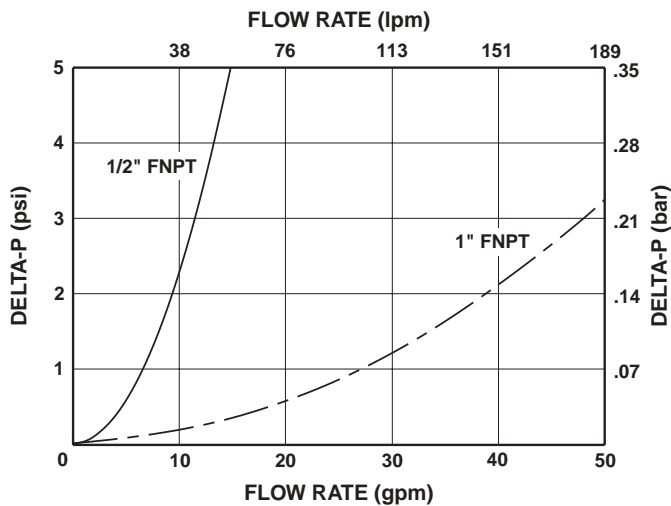

PRESSURE DROP VS. FLOW RATE

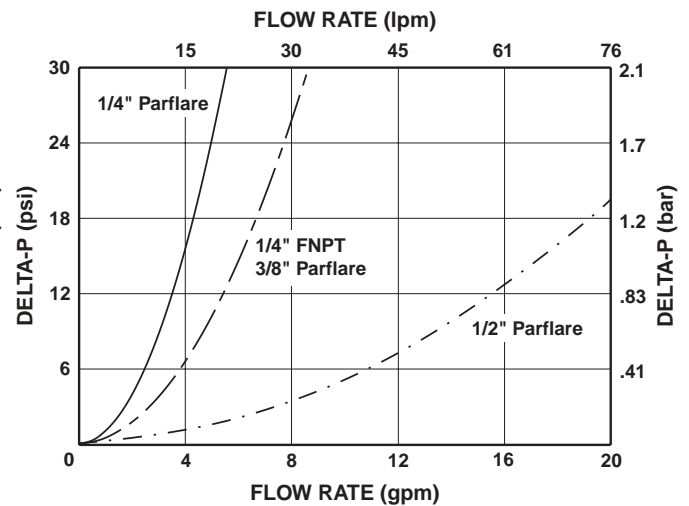

MV-7 Manual Plug Valve

Product Overview

The MV-7 Tapered Plug Valve is designed for use in high purity semiconductor applications, and is also ideally suited for ultra-pure water and aggressive chemicals. A precision-machined PTFE body with a straight through roddable flowpath is combined with a PTFE tapered plug for maximum flow, minimum pressure drop and bubble-tight shut off.



Features

Precision-machined PTFE tapered plug seated onto a roddable PTFE body with a straight through flowpath.

Panel mounting an option on all sizes.

Benefits

Bubble-tight shut off.

Maximum flow with minimum pressure drop.

Ideal for process instrumentation applications.

Specifications

Materials of Construction:

Wetted Surfaces - PTFE

Non Wetted Surfaces - Anodized Aluminum, ABS, PFA, PVDF.

Pressure Ranges:

0 to 120 PSIG (8.3 bar)

Pressure ranges above are for operation at ambient temperature. For use at higher temperatures consult Pressure/Temperature chart on page 3.

Temperature Ranges:

-60° - 176° F (-51° - 80° C) Ambient

-60° - 400° F (-51° - 204° C) Fluid

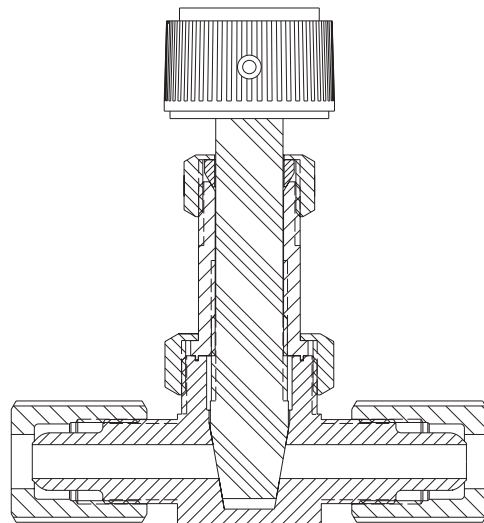

MV-7 Manual Plug Valve

BRACKETED DIMENSIONS ARE IN mm.

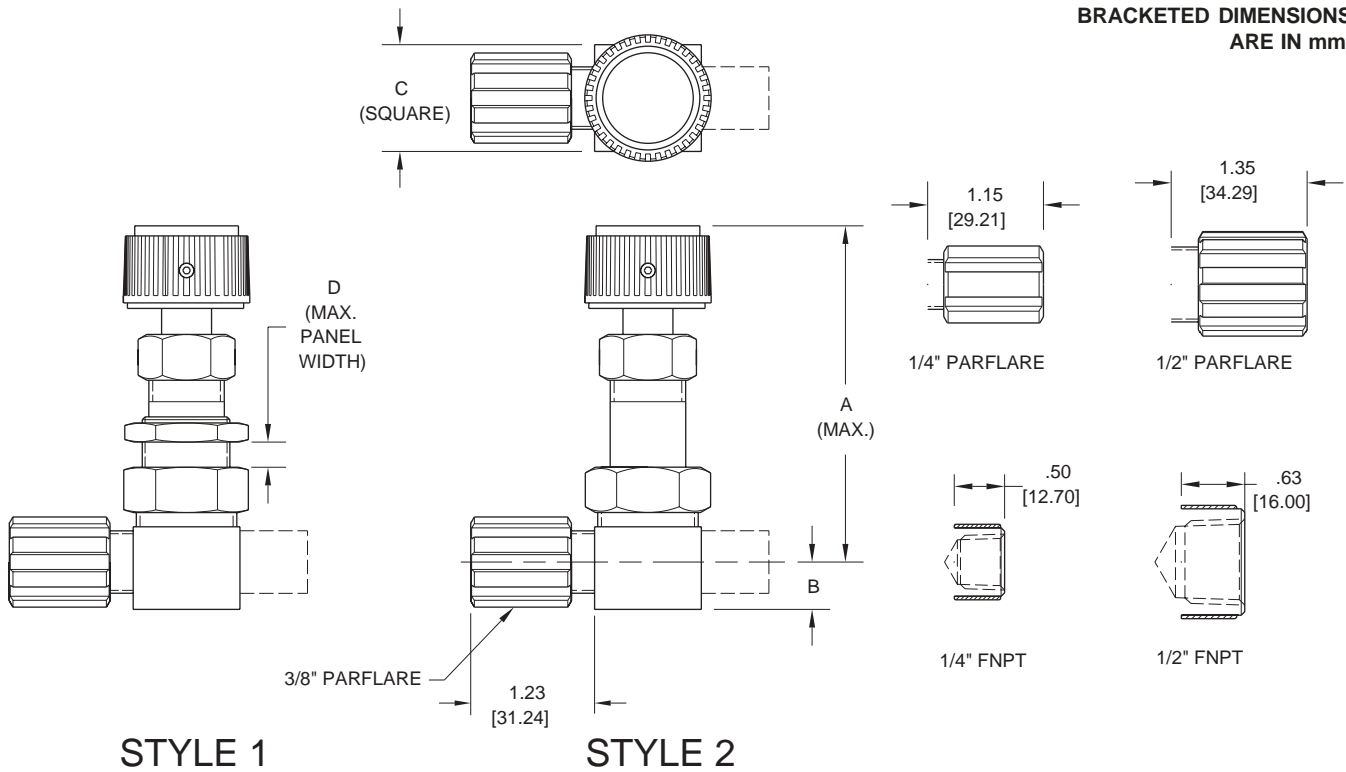

STYLE 1

STYLE 2

STYLE	DIMENSIONS (in.)				DIMENSIONS (mm.)				
	A	B	C	D	A	B	C	D	
MV-7-1414-0	2	3.69	.47	1.06	N/A	93.73	11.94	26.92	N/A
MV-7-1818-0	2	5.06	.59	1.63	N/A	128.52	14.99	41.40	N/A
MV-7-6214-0	2	3.69	.47	1.06	N/A	93.73	11.94	26.92	N/A
MV-7-6416-0	2	3.69	.47	1.06	N/A	93.73	11.94	26.92	N/A
MV-7-6416-1	1	3.69	.47	1.06	.25	93.73	11.94	26.92	6.35
MV-7-6618-0	2	5.06	.59	1.63	N/A	128.52	14.99	41.40	N/A

Model Number	Cv	Kv	Flow Config.	Port Configuration
MV-7-1414-0	1.17	16.7	ON/OFF	1/4" FNPT
MV-7-1818-0	7.68	109.5	"	1/2" FNPT
MV-7-6214-0	.25	3.6	"	1/4" Parflare

Model Number	Cv	Kv	Flow Config.	Port Configuration
MV-7-6416-0	1.33	19.0	ON/OFF	3/8" Parflare
MV-7-6416-1	1.33	19.0	"	3/8" Parflare
MV-7-6618-0	3.56	50.8	"	1/2" Parflare

C_v / K_v vs. Turns

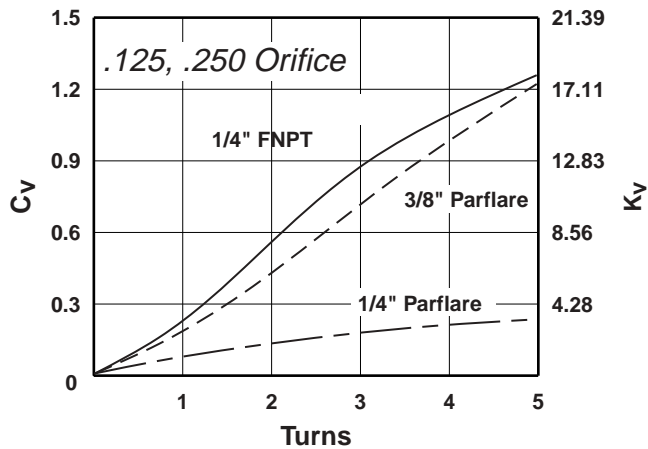

C_v / K_v vs. Turns

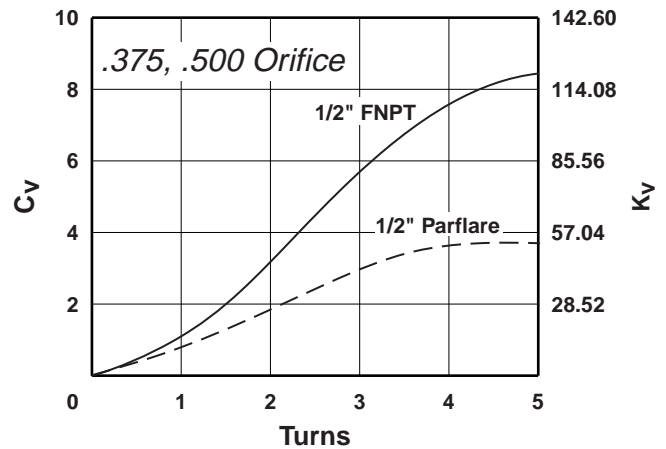

MV-8 Manual Sampling Valve

Product Overview

The MV-8 Sampling Valve is designed for use in high purity semiconductor applications, and is also ideally suited for ultra-pure water or aggressive chemicals. The design utilizes a machined PTFE body with precision machined seat and diaphragm sealing areas. A one piece machined modified PTFE diaphragm is also utilized for excellent flexibility and life. The valve incorporates a full flow through port with a low dead volume down leg. The purge port option makes this the valve of choice for valve manifold boxes and distribution systems.



Features

One piece precision machined diaphragm manufactured from the latest technology modified PTFE, provides over five times the flexural life as compared to conventional PTFE.

Full flow through port.

Purge port option.

Benefits

Higher cycle life resulting in less downtime and lower replacement costs.

Reduced pressure drop.

Allows system maintenance downstream of valve without disrupting main flow.

Specifications

Materials of Construction:

Wetted Surfaces - PTFE, Modified PTFE
External Surfaces - PVDF

Pressure Range:

27" Hg vacuum (913 mbar) to 120 PSIG (8.3 bar)

Pressure ranges above are for operation at ambient temperature. For use at higher temperatures consult Pressure/Temperature chart on page 3.

Temperature Ranges:

0° - 212° F (17° - 100° C) Ambient

0° - 400° F (17° - 204° C) Fluid

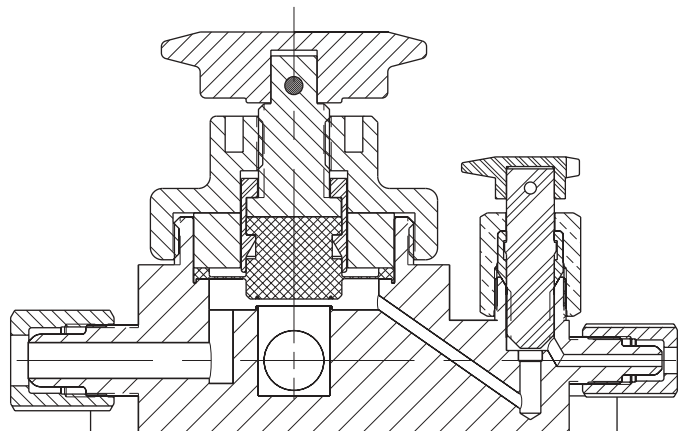

MV-8 Manual Sampling Valve

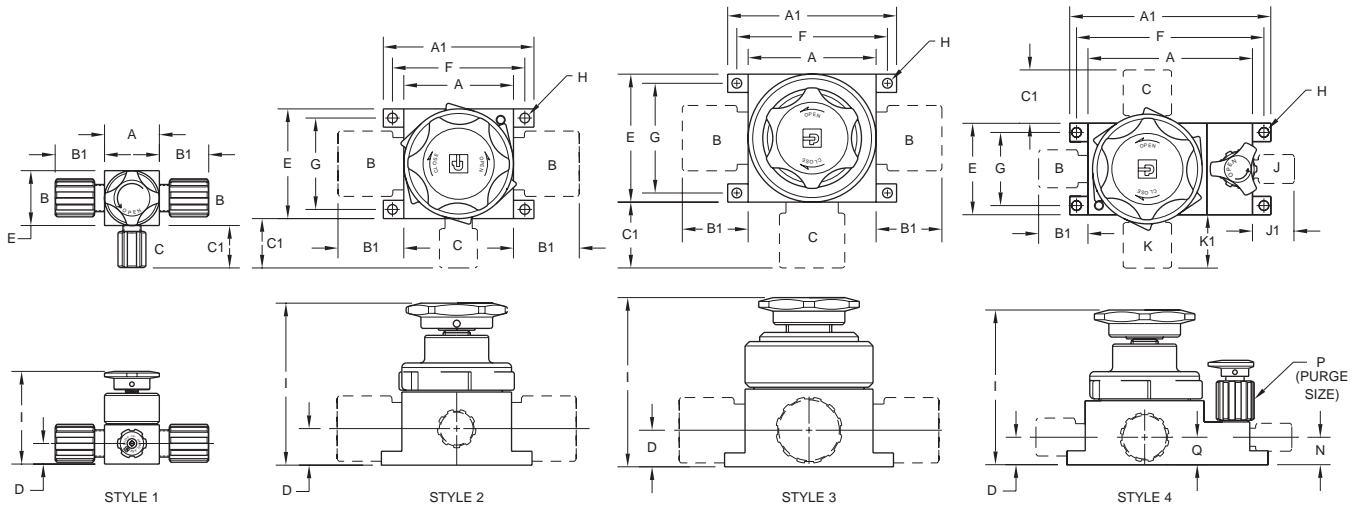

DIMENSIONS (in)

STYLE	A	A1	B	B1	C	C1	D	E	F	G	H	I	J	J1	K	K1	N	P	Q	
MV-8-6684-1	1	1.50	-	1/2"	1.35	1/4"	1.15	.56	1.50	-	-	-	2.57							
MV-8-661612	2	3.00	4.12	1"	1.80	3/4"	1.46	1.00	3.00	3.62	2.50	Ø .266	4.51							
MV-8-661212-1	2	3.50	4.62	3/4"	1.46	3/4"	1.46	1.00	3.50	4.12	3.00	Ø .266	4.51							
MV-8-66128-1	2	3.00	4.12	3/4"	1.46	1/2"	1.35	1.00	3.00	3.62	2.50	Ø .266	4.51							
MV-8-66164-1	2	3.00	4.12	1"	1.80	1/4"	1.15	1.00	3.00	3.62	2.50	Ø .266	4.51							
MV-8-661616-1	3	3.50	4.62	1"	1.80	1"	1.80	1.00	3.50	4.12	3.00	Ø .266	4.63							
MV-8-66128-1-01	4	4.50	5.50	1/2"	1.35	3/4"	1.46	.75	2.50	5.13	2.00	Ø .266	4.50	1/4"	1.15	3/4"	1.46	.75	1/4"	.75
MV-8-66128-1-05	4	4.63	5.75	1/2"	1.35	3/4"	1.46	.75	2.50	5.37	2.00	Ø .266	4.50	1/2"	1.35	3/4"	1.46	.88	1/2"	.92
MV-8-661212-1-01	4	4.50	5.50	3/4"	1.46	3/4"	1.46	.75	2.50	5.13	2.00	Ø .266	4.50	1/4"	1.15	3/4"	1.46	.75	1/4"	.75
MV-8-66168-1-01	4	4.63	5.75	1/2"	1.35	1"	1.80	.75	3.00	5.37	2.00	Ø .266	4.60	1/2"	1.35	1"	1.80	.88	1/2"	.92
MV-8-661612-1-01	4	4.50	5.50	3/4"	1.46	1"	1.80	.93	3.00	5.13	2.04	Ø .266	4.60	1/4"	1.15	1"	1.80	.75	1/4"	.93
MV-8-661616-1-01	4	4.50	5.50	1"	1.80	1"	1.80	.93	3.00	5.13	2.54	Ø .266	4.60	1/4"	1.15	1"	1.80	.75	1/4"	.93
MV-8-66208-1-01	4	4.63	5.75	1/2"	1.35	1 1/4"	2.16	.75	3.00	5.37	2.50	Ø .266	4.85	1/2"	1.35	1 1/4"	2.16	.88	1/2"	.88

DIMENSIONS (mm)

STYLE	A	A1	B	B1	C	C1	D	E	F	G	H	I	J	J1	K	K1	N	P	Q	
MV-8-6684-1	1	38.1	-	1/2"	34.3	1/4"	29.2	14.2	38.1	-	-	-	65.3							
MV-8-661612	2	76.2	104.6	1"	45.7	3/4"	37.1	25.4	76.2	91.9	63.5	Ø 6.76	114.6							
MV-8-661212-1	2	88.9	117.3	3/4"	37.1	3/4"	37.1	25.4	88.9	104.6	76.2	Ø 6.76	114.6							
MV-8-66128-1	2	76.2	104.6	3/4"	37.1	1/2"	34.3	25.4	76.2	91.9	63.5	Ø 6.76	114.6							
MV-8-66164-1	2	76.2	104.6	1"	45.7	1/4"	29.2	25.4	76.2	91.9	63.5	Ø 6.76	114.6							
MV-8-661616-1	3	88.9	104.6	1"	45.7	1"	45.7	25.4	88.9	104.6	76.2	Ø 6.76	117.6							
MV-8-66128-1-01	4	114.3	139.7	1/2"	34.3	3/4"	37.1	19.1	63.5	130.3	50.8	Ø 6.76	114.3	1/4"	29.2	3/4"	37.1	19.1	1/4"	19.1
MV-8-66128-1-05	4	117.6	146.0	1/2"	34.3	3/4"	37.1	19.1	63.5	136.4	50.8	Ø 6.76	114.3	1/2"	34.3	3/4"	37.1	22.4	1/2"	23.4
MV-8-661212-1-01	4	114.3	139.7	3/4"	37.1	3/4"	37.1	19.1	63.5	130.3	50.8	Ø 6.76	114.3	1/4"	29.2	3/4"	37.1	19.1	1/4"	19.1
MV-8-66168-1-01	4	117.6	146.0	1/2"	34.3	1"	45.7	19.1	76.2	136.4	50.8	Ø 6.76	116.8	1/2"	34.3	1"	45.7	22.4	1/2"	23.4
MV-8-661612-1-01	4	114.3	139.7	3/4"	37.1	1"	45.7	23.6	76.2	130.3	51.8	Ø 6.76	116.8	1/4"	29.2	1"	45.7	19.1	1/4"	23.6
MV-8-661616-1-01	4	114.3	139.7	1"	45.7	1"	45.7	23.6	76.2	130.3	64.5	Ø 6.76	116.8	1/4"	29.2	1"	45.7	19.1	1/4"	23.6
MV-8-66208-1-01	4	117.6	146.0	1/2"	34.3	1 1/4"	54.9	19.1	76.2	136.4	63.5	Ø 6.76	123.9	1/2"	34.3	1 1/4"	54.9	22.4	1/2"	22.4

Model Number	Through Port		Sampling Port		Purge Port		Through Port	Sampling Port	Purge Port
	Cv	Kv	Cv	Kv	Cv	Kv			
MV-8-6684-1	3.2	45.7	.2	2.8	N/A	N/A	1/2" Parflare	1/4" Parflare	N/A
MV-8-661612	37.3	532.6	4.6	65.7	N/A	N/A	1" Parflare	3/4" Parflare	N/A
MV-8-661212-1	13.0	185.6	4.6	65.7	N/A	N/A	3/4" Parflare	3/4" Parflare	N/A
MV-8-66128-1	13.0	185.6	2.3	32.8	N/A	N/A	3/4" Parflare	1/2" Parflare	N/A
MV-8-66164-1	37.3	532.6	.2	2.8	N/A	N/A	1" Parflare	1/4" Parflare	N/A
MV-8-661616-1	37.3	532.6	7.2	102.8	N/A	N/A	1" Parflare	1" Parflare	N/A
MV-8-66128-1-01	13.0	185.6	2.3	32.8	.2	2.8	3/4" Parflare	1/2" Parflare	1/4" Parflare
MV-8-66128-1-05	13.0	185.6	2.3	32.8	1.1	15.7	3/4" Parflare	1/2" Parflare	1/2" Parflare
MV-8-661212-1-01	13.0	185.6	4.6	65.7	.2	2.8	3/4" Parflare	3/4" Parflare	1/4" Parflare
MV-8-66168-1-01	37.3	532.6	2.3	32.8	1.1	15.7	1" Parflare	1/2" Parflare	1/2" Parflare
MV-8-661612-1-01	37.3	532.6	4.6	65.7	.2	2.8	1" Parflare	3/4" Parflare	1/4" Parflare
MV-8-661616-1-01	37.3	532.6	7.2	102.8	.2	2.8	1" Parflare	1" Parflare	1/4" Parflare
MV-8-66208-1-01	55.0	785.4	2.3	32.8	1.1	15.7	1 1/4" Parflare	1/2" Parflare	1/2" Parflare

Numerous sizes and configurations are available. Please consult factory for other available configurations or custom assemblies.

MV-10 1/4" Manual Valve

Product Overview

The MV-10 2 Way Diaphragm Valve is designed for use in high purity semiconductor applications. It is also ideally suited for ultra-pure water and aggressive chemical or gas applications. The design utilizes a molded high purity PFA body with precision machined sealing areas. A one piece machined modified PTFE diaphragm is also utilized for excellent flexibility and life. A full 1/4" orifice provides maximum flow capability in a compact package.



Features

One piece precision machined diaphragms manufactured from the latest technology modified PTFE.

Provides over five times the flexural life as compared to conventional PTFE.

Tongue and groove seat and diaphragm for positive through flow shut off and diaphragm to body seal.

PVDF coated stainless steel spring.

Quarter turn operation with removable handle for tamper resistance.

Benefits

High cycle life.

Lower replacement costs.

Less downtime.

Reduces effects of corrosive environments.

Eliminates need for separate lockout device.

Specifications

Materials of Construction:

Wetted Surfaces - PFA, Modified PTFE

External Surfaces - PFA, PVDF, 18-8 stainless steel

Other Materials - Viton seals, PVDF coated stainless steel springs.

Pressure Ranges:

Forward - 27" Hg vacuum (913 mbar) to 80 PSIG (5.5 bar)

Back - 27" Hg vacuum (913 mbar) to 80 PSIG (5.5 bar)

Pressure ranges above are for operation at ambient temperature. For use at higher temperatures consult Pressure/Temperature chart on page 3.

Temperature Ranges:

0° - 150° F (-17° - 66° C) Ambient

0° - 266° F (-17° - 130° C) Fluid

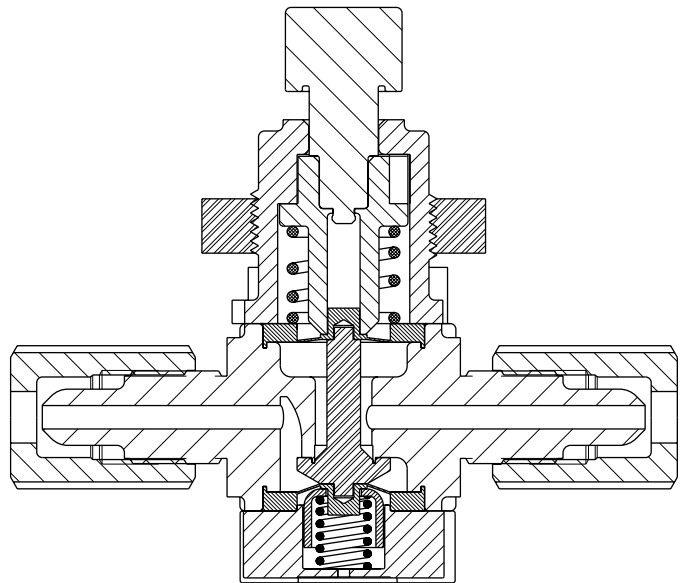

MV-10 1/4" Manual Valve

BRACKETED DIMENSIONS
ARE IN mm.

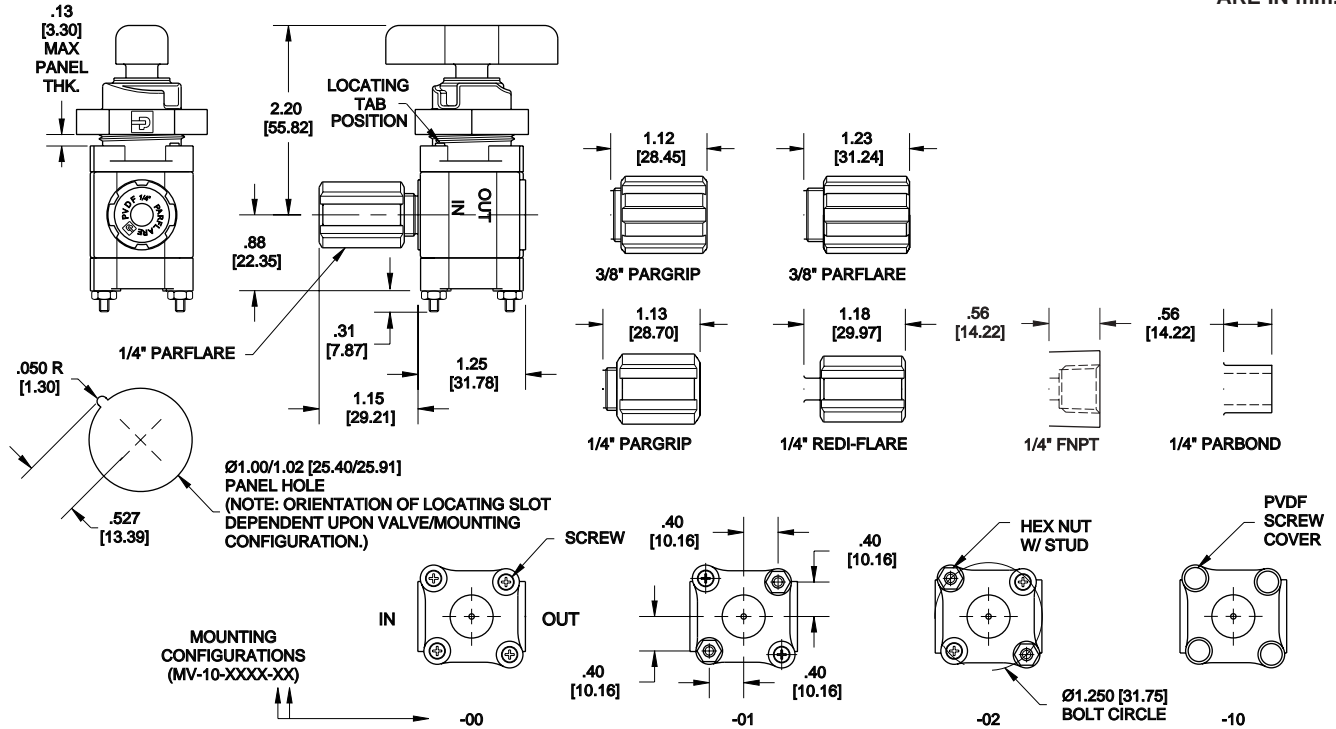

Model Number	Cv	Kv	Flow Config.	Inlet Port	Outlet Port
MV-10-1044-XX	.60	8.6	ON/OFF	1/4" FNPT	1/4" FNPT
MV-10-2034-XX	.24	3.4	"	1/4" Pargrip	1/4" Pargrip
MV-10-2046-XX	.62	8.8	"	3/8" Pargrip	3/8" Pargrip
MV-10-6024-XX	.20	2.8	"	1/4" Parflare	1/4" Parflare
MV-10-6024-XX-20	.20	2.8	"	1/4" Redi-flare	1/4" Parflare

Model Number	Cv	Kv	Flow Config.	Inlet Port	Outlet Port
MV-10-6024-XX-21	.20	2.8	ON/OFF	1/4" Parflare	1/4" Redi-flare
MV-10-6046-XX	.62	8.8	"	3/8" Parflare	3/8" Parflare
MV-10-6046-XX-20	.62	8.8	"	3/8" Redi-flare	3/8" Parflare
MV-10-6046-XX-21	.62	8.8	"	3/8" Parflare	3/8" Redi-flare
MV-10-7044-XX	.62	8.8	"	1/4" Parbond	1/4" Parbond

Above Pargrip model numbers are supplied with PFA nuts. Parflare models are supplied with PVDF nuts. For PFA nuts add -T as the final suffix to the model number (i.e. MV-10-6024-02-T). Please consult factory for other available configurations or custom assemblies.

PRESSURE DROP VS. FLOW RATE

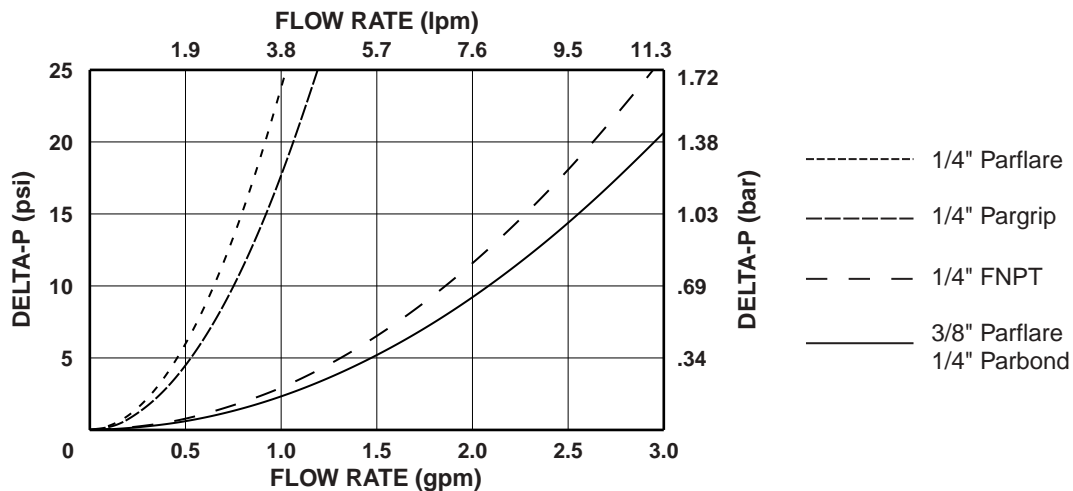

MV-10 1/4" Manual Valve

Product Overview

The MV-10 3 Way Diaphragm Valve is designed for use in high purity semiconductor applications. It is also ideally suited for ultra-pure water and aggressive chemical or gas applications. The design utilizes a molded high purity PFA body with precision machined sealing areas. A one piece machined modified PTFE diaphragm is also utilized for excellent flexibility and life. A full 1/4" orifice provides maximum flow capability in a compact package.



Features

One piece precision machined diaphragms manufactured from the latest technology modified PTFE.

Provides over five times the flexural life as compared to conventional PTFE.

Tongue and groove seat and diaphragm for positive through flow shut off and diaphragm to body seal.

PVDF coated stainless steel spring.

Quarter turn operation with removable handle for tamper resistance.

Benefits

High cycle life.

Lower replacement costs.

Less downtime.

Reduces effects of corrosive environments.

Eliminates need for separate lockout device.

Specifications

Materials of Construction:

Wetted Surfaces - PFA, Modified PTFE

External Surfaces - PFA, PVDF, 18-8 stainless steel

Other Materials - Viton seals, PVDF coated stainless steel springs.

Pressure Ranges:

Forward - 27" Hg vacuum (913 mbar) to 80 PSIG (5.5 bar)

Back - 27" Hg vacuum (913 mbar) to 80 PSIG (5.5 bar)

Pressure ranges above are for operation at ambient temperature. For use at higher temperatures consult Pressure/Temperature chart on page 3.

Temperature Ranges:

0° - 150° F (-17° - 66° C) Ambient

0° - 266° F (-17° - 130° C) Fluid

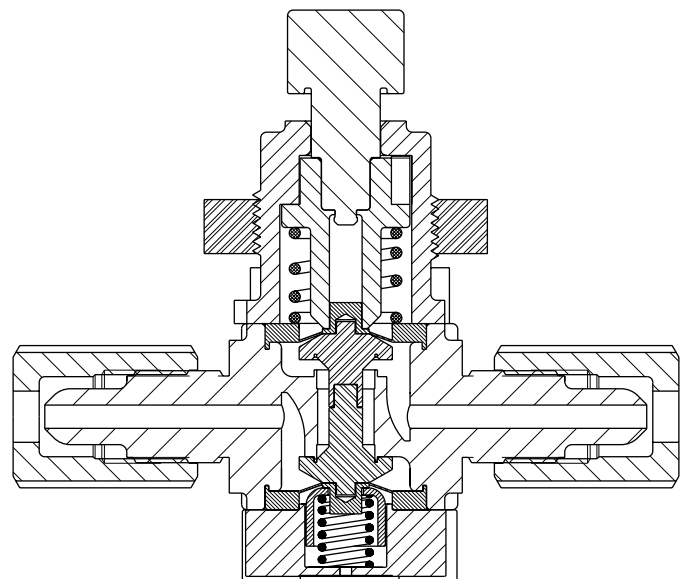

MV-10 1/4" Manual Valve

BRACKETED DIMENSIONS ARE IN mm.

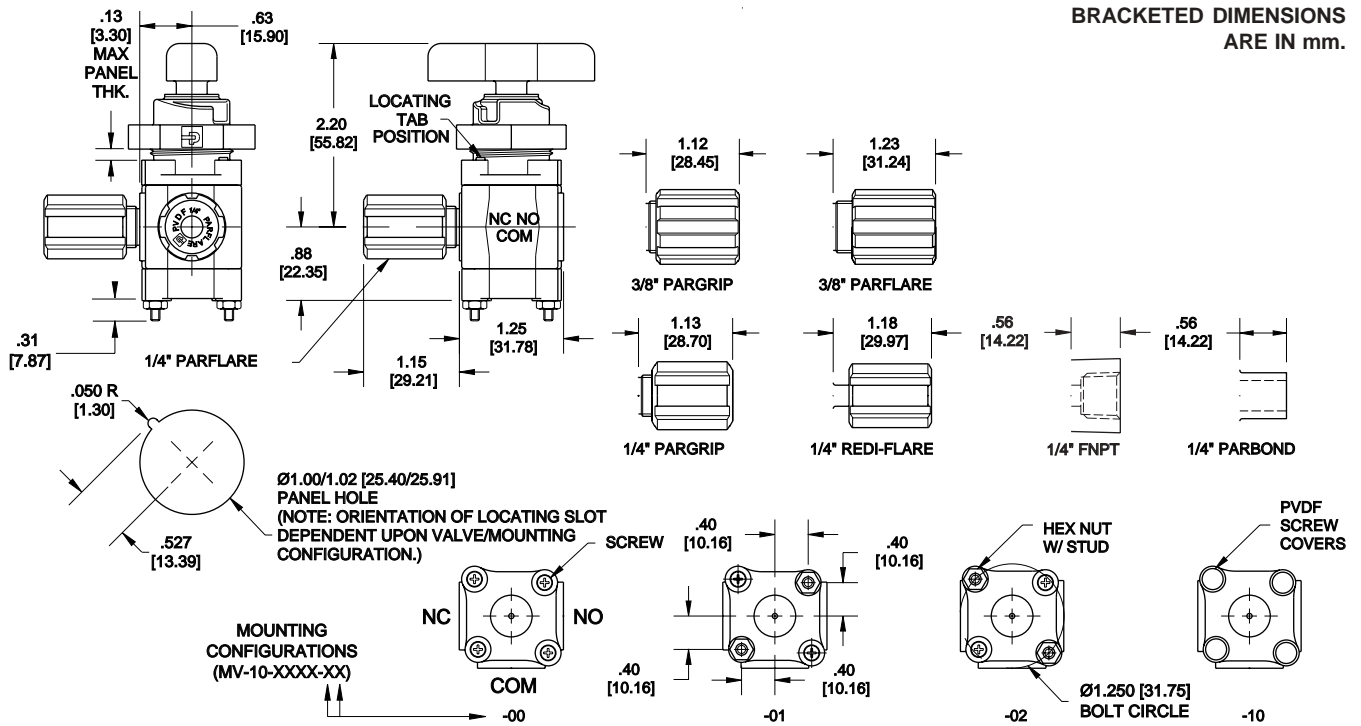

Model Number	Cv	Kv	Flow Configuration	Port Configuration
MV-10-1344-XX	.60	8.6	3 WAY	1/4" FNPT
MV-10-2346-XX	.62	8.8	"	3/8" Pargrip
MV-10-6324-XX	.20	2.8	"	1/4" Parflare
MV-10-6346-XX	.62	8.8	"	3/8" Parflare
MV-10-7344-XX	.62	8.8	"	1/4" Parbond

Above Pargrip model numbers are supplied with PFA nuts. Parflare models are supplied with PVDF nuts. For PFA nuts add -T as the final suffix to the model number (i.e. MV-10-6324-02-T). Please consult factory for other available configurations or custom assemblies.

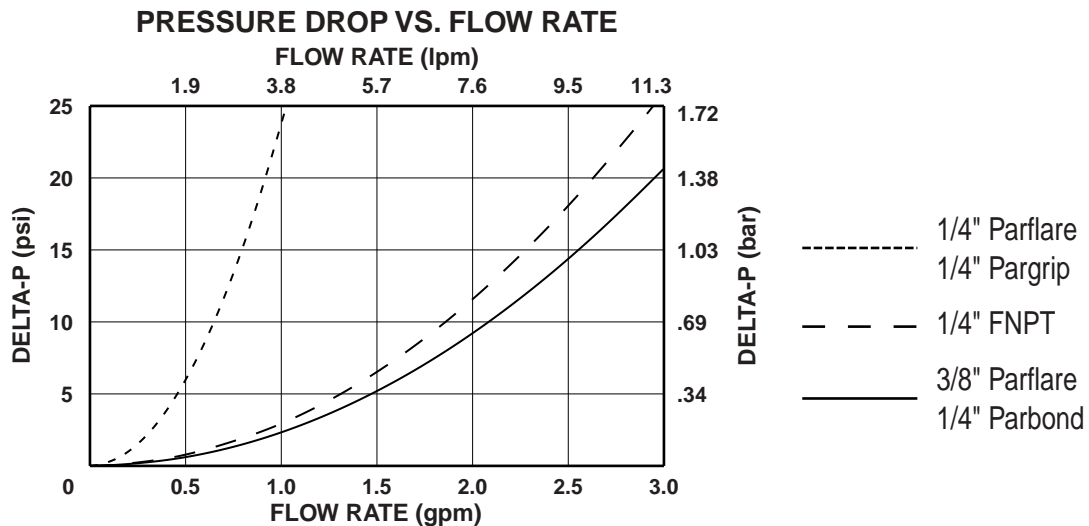

MV-11 1/2" Manual Valve

Product Overview

The MV-11 2 Way Diaphragm Valve is designed for use in high purity semiconductor applications. It is also ideally suited for ultra-pure water and aggressive chemical or gas applications. The design utilizes a molded high purity PFA body with precision machined sealing areas. A one piece machined modified PTFE diaphragm is also utilized for excellent flexibility and life. A full 1/2" orifice provides maximum flow capability in a compact package.



Features

One piece precision machined diaphragm manufactured from the latest technology modified PTFE.

Provides over five times the flexural life as compared to conventional PTFE.

Tongue and groove seat and diaphragm for positive through flow shut off and diaphragm to body seal.

PVDF coated stainless steel spring.

Submersible option isolates all valve components from the external environment.

Benefits

High cycle life.

Lower replacement costs.

Less downtime.

Reduces effects of corrosive environments.

Valve remains functional while operating in wet or gaseous corrosive environments.

Specifications

Materials of Construction:

Wetted Surfaces - PFA, Modified PTFE

External Surfaces - PFA, PVDF

Other Materials - Viton Seals, PVDF coated stainless spring

Pressure Ranges:

Forward - 27" Hg vacuum (913 mbar) to 100 PSIG (7 bar)

Back - 27" Hg Vacuum (913 mbar) to 100 PSIG (7 bar)

Pressure ranges above are for operation at ambient temperature. For use at higher temperatures consult Pressure/Temperature chart on page 3.

Temperature Ranges:

0° - 150° F (-17° - 66° C) Ambient

0° - 266° F (-17° - 130° C) Fluid

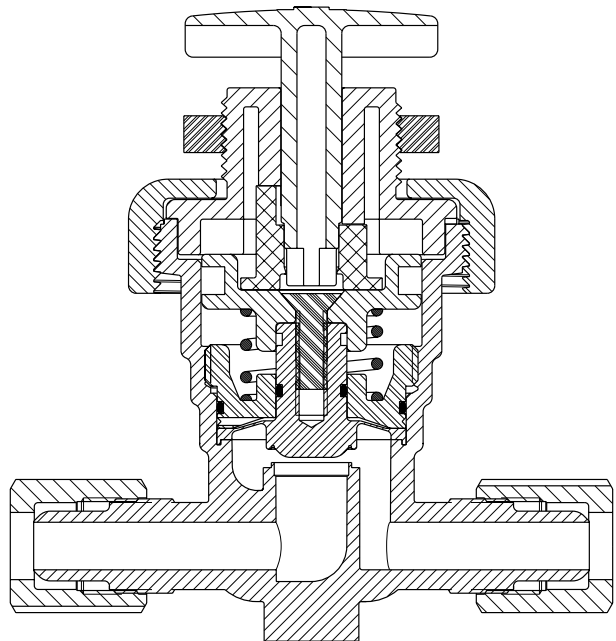

MV-11 1/2" Manual Valve

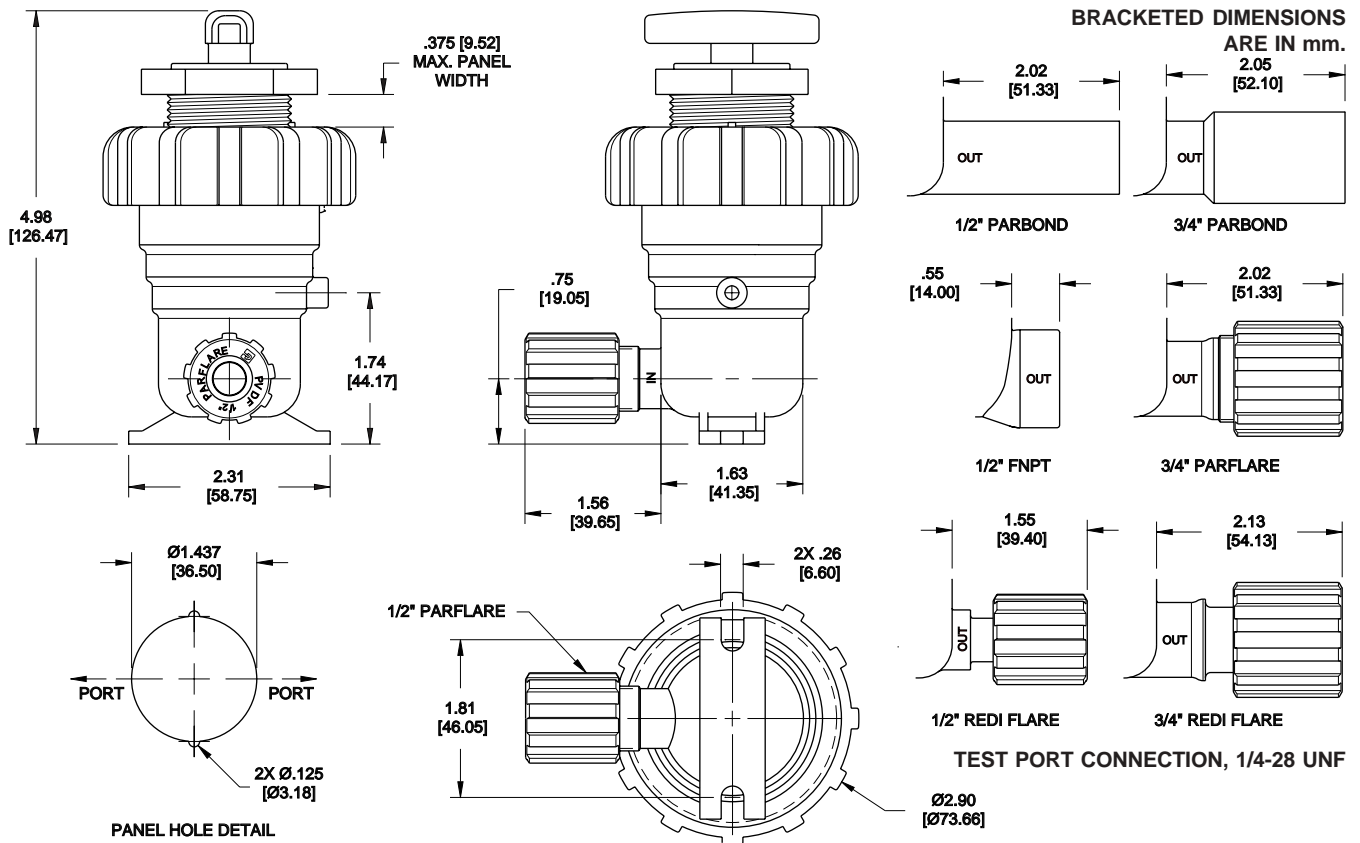

Model Number	C _v	K _v	Flow Configuration	Inlet Port	Outlet Port
MV-11-001	2.3	32.8	ON/OFF	1/2" Parflare	1/2" Parflare
MV-11-002	3.7	52.8	"	3/4" Parflare	3/4" Parflare
MV-11-003	3.7	52.8	"	1/2" Parbond	1/2" Parbond
MV-11-004	3.7	52.8	"	3/4" Parbond	3/4" Parbond
MV-11-005	3.7	52.8	"	1/2" FNPT	1/2" FNPT
MV-11-008	2.3	32.8	"	1/2" Redi-flare	1/2" Redi-flare
MV-11-008-01	2.3	32.8	"	1/2" Redi-flare	1/2" Parflare
MV-11-009	3.7	52.8	"	3/4" Redi-flare	3/4" Redi-flare
MV-11-009-01	3.7	52.8	"	3/4" Redi-flare	3/4" Parflare

Above Parflare model numbers are supplied with PVDF nuts. For PFA nuts add -T to model number. For high temperature nut assemblies, add -HT. Consult factory for delivery and pricing. Please consult factory for other available configurations, custom assemblies or leak sensor assemblies.

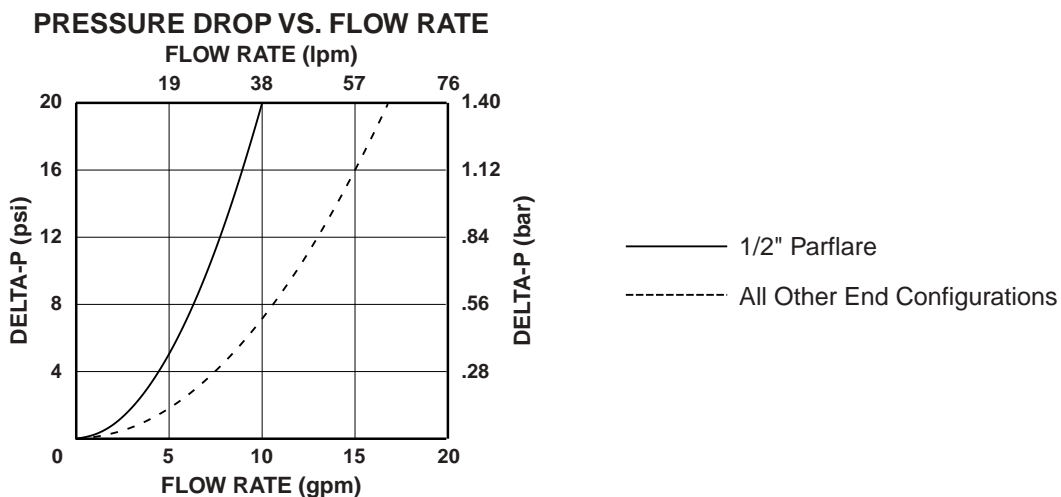

Product Overview

The MV-11 3 Way Diaphragm Valve is designed for use in high purity semiconductor applications. It is also ideally suited for ultra-pure water and aggressive chemical or gas applications. The design utilizes a molded high purity PFA body with precision machined sealing areas. One piece machined modified PTFE diaphragms are also utilized for excellent flexibility and life. A full 1/2" orifice provides maximum flow capability in a compact package.



Features

One piece precision machined diaphragm manufactured from the latest technology modified PTFE.

Provides over five times the flexural life as compared to conventional PTFE.

Tongue and groove seat and diaphragm for positive through flow shut off and diaphragm to body seal.

PVDF coated stainless steel spring.

Submergible option isolates all valve components from the external environment.

Benefits

High cycle life.

Lower replacement costs.

Less downtime.

Reduces effects of corrosive environments.

Valve remains functional while operating in wet or gaseous corrosive environments.

Specifications

Materials of Construction:

Wetted Surfaces - PFA, Modified PTFE

External Surfaces - PFA, PVDF

Other Materials - Viton Seals, PVDF coated stainless spring

Pressure Ranges:

From COM Port to N.O. Port - 27" Hg vacuum (913 mbar) to 80 PSIG (5.5 bar)

From COM Port to N.C. Port - 27" Hg vacuum (913 mbar) to 25 PSIG (1.7 bar) minimum.

From N.C. Port to COM Port - 27" Hg vacuum (913 mbar) to 50 PSIG (3.4 bar) minimum.

Pressure ranges above are for operation at ambient temperature. For use at higher temperatures consult Pressure/Temperature chart on page 3.

Temperature Ranges:

0° - 150° F (-17° - 66° C) Ambient

0° - 266° F (-17° - 130° C) Fluid

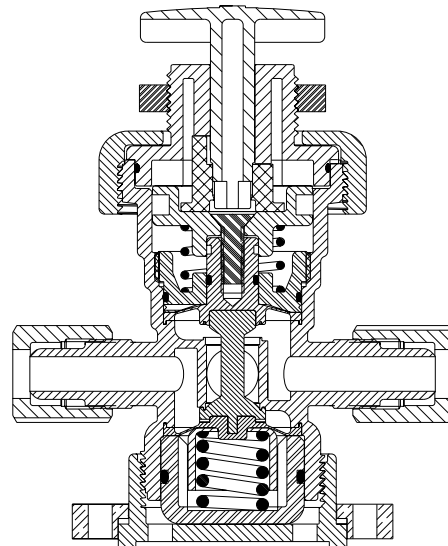

MV-11 1/2" Manual Valve

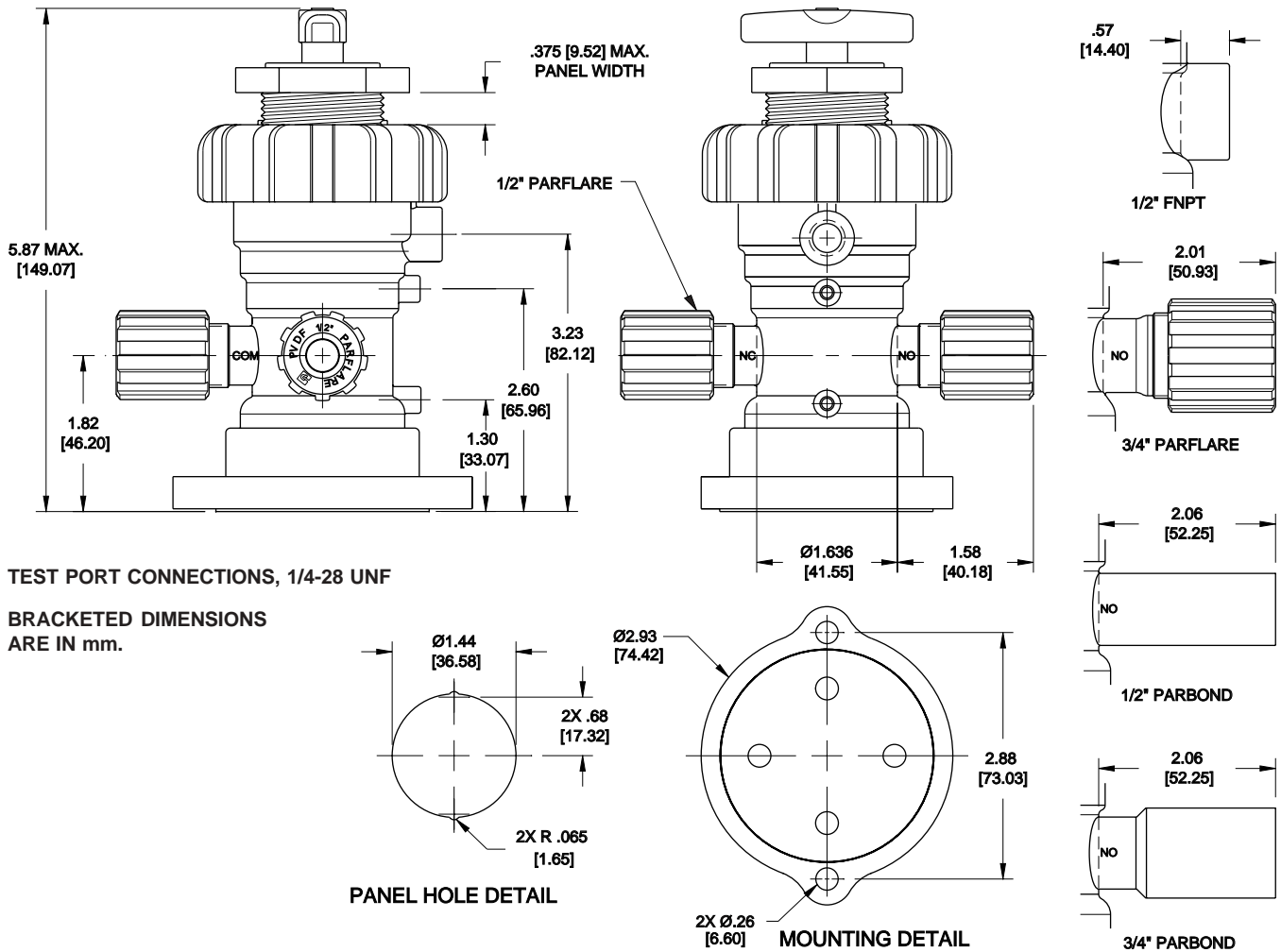

Model Number	Cv	Kv	Flow Configuration	Port Configuration
MV-11-021	1.9	27.1	3 WAY	1/2" Parflare
MV-11-022	2.8	40.0	"	3/4" Parflare
MV-11-023	2.8	40.0	"	1/2" Parbond
MV-11-024	2.8	40.0	"	3/4" Parbond
MV-11-025	2.8	40.0	"	1/2" FNPT

Above Parflare model numbers are supplied with PVDF nuts. For PFA nuts add -T to model number. For high temperature nut assemblies, add -HT. Consult factory for delivery and pricing. Please consult factory for other available configurations, custom assemblies or leak sensor assemblies.

PRESSURE DROP VS. FLOW RATE

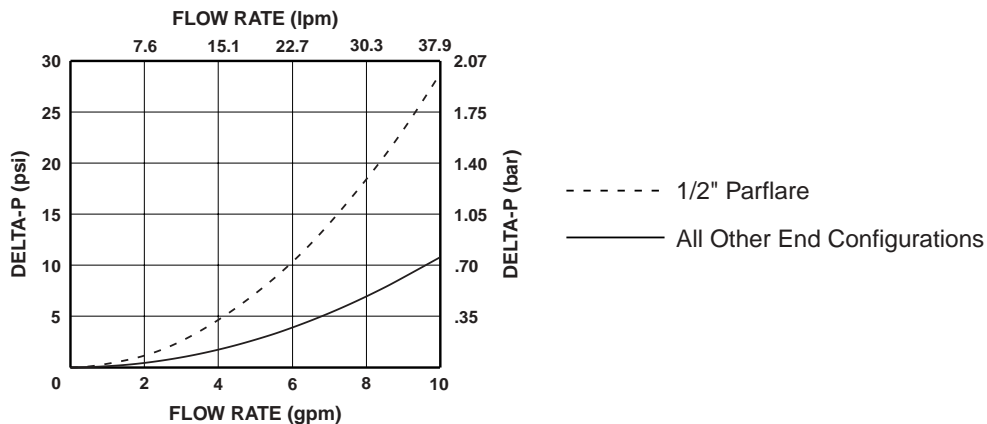

MV-11 1/2" Manual Valve

Product Overview

The MV-11 Adjustable Diaphragm Valve is designed for use in high purity semiconductor applications. It is also ideally suited for ultra-pure water and aggressive chemical or gas applications. The design utilizes a molded high purity PFA body with precision machined sealing areas. A one piece machined modified PTFE diaphragm is also utilized for excellent flexibility and life. Multi-turn capability allows precise flow adjustment. A full 1/2" orifice provides maximum flow capability in a compact package.



Features

One piece precision machined diaphragm manufactured from the latest technology modified PTFE. Provides over five times the flexural life as compared to conventional PTFE. Tongue and groove diaphragm to body seal assures leak free operation.

PVDF coated stainless steel spring.

Multi-turn operation.

Removable handle.

Benefits

High cycle life.

Lower replacement costs.

Less downtime.

Reduces effects of corrosive environments.

Precise flow adjustment.

Eliminates need for separate lockout device.

Specifications

Materials of Construction:

Wetted Surfaces - PFA, Modified PTFE

External Surfaces - PFA, PVDF

Other Materials - Viton Seals, PVDF coated stainless spring

Pressure Ranges:

Forward - 27" Hg vacuum (913 mbar) to 100 PSIG (7 bar)

Back - 27" Hg Vacuum (913 mbar) to 100 PSIG (7 bar)

Pressure ranges above are for operation at ambient temperature. For use at higher temperatures consult Pressure/Temperature chart on page 3.

Temperature Ranges:

0° - 150° F (-17° - 66° C) Ambient

0° - 266° F (-17° - 130° C) Fluid

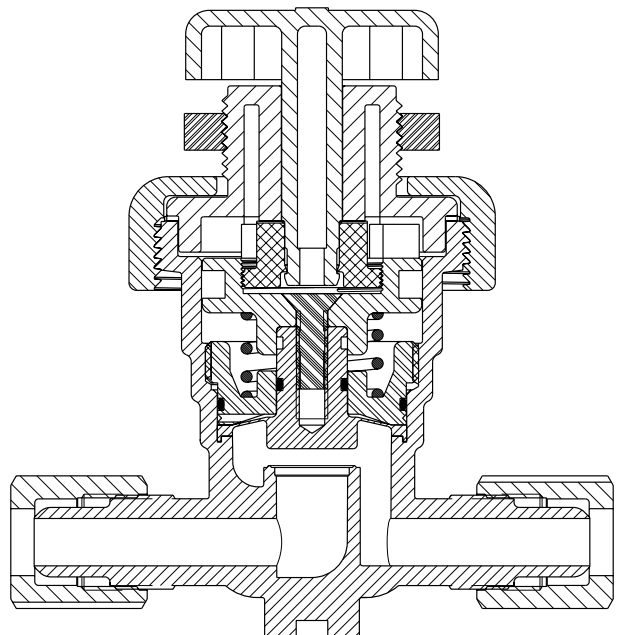

MV-11 1/2" Manual Valve

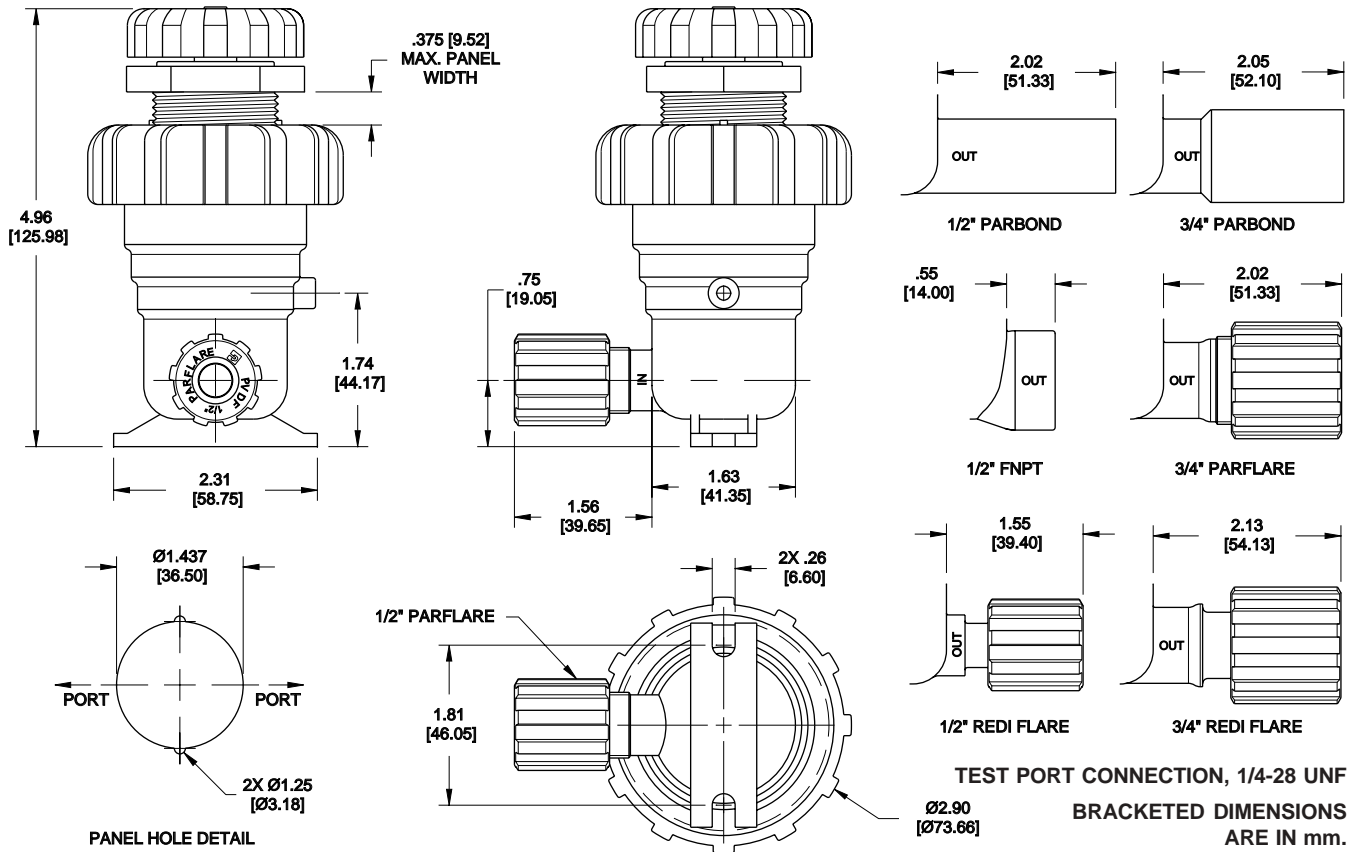

Model Number	Cv	Kv	Flow Configuration	Inlet Port	Outlet Port
MV-11-201	2.3	32.8	ADJ.	1/2" Parflare	1/2" Parflare
MV-11-202	3.7	52.8	"	3/4" Parflare	3/4" Parflare
MV-11-203	3.7	52.8	"	1/2" Parbond	1/2" Parbond
MV-11-204	3.7	52.8	"	3/4" Parbond	3/4" Parbond
MV-11-205	3.7	52.8	"	1/2" FNPT	1/2" FNPT
MV-11-208	2.3	32.8	"	1/2" Redi-flare	1/2" Redi-flare
MV-11-208-01	2.3	32.8	"	1/2" Redi-flare	1/2" Parflare
MV-11-209	3.7	52.8	"	3/4" Redi-flare	3/4" Redi-flare
MV-11-209-01	3.7	52.8	"	3/4" Redi-flare	3/4" Parflare

Above Parflare model numbers are supplied with PVDF nuts. For PFA nuts add -T to model number. For high temperature nut assemblies, add -HT. Consult factory for delivery and pricing. Please consult factory for other available configurations, custom assemblies or leak sensor assemblies.

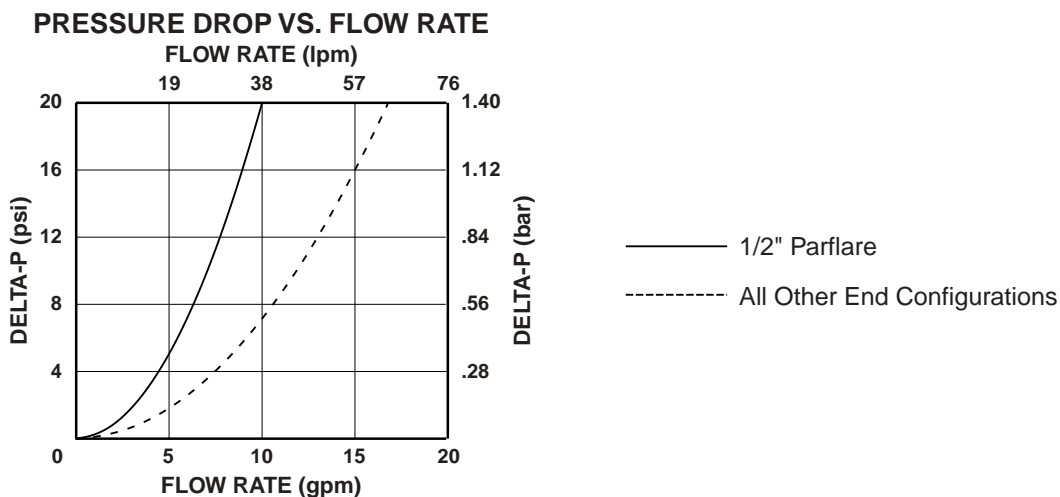

MV-12 1" Manual Valve

Product Overview

The MV-12 Diaphragm Valve is designed for use in high purity semiconductor applications, and is also ideally suited for ultra-pure water and aggressive chemical or gas applications. The design utilizes a molded high purity PFA body with precision machined seat and diaphragm sealing areas. A one piece machined modified PTFE diaphragm is also utilized for excellent flexibility and life. The valve requires three full turns from the fully closed to fully open position. A full 1" orifice provides maximum flow capability in a compact package.



Features

One piece precision machined diaphragm manufactured from the latest technology modified PTFE.

Provides over five times the flexural life as compared to conventional PTFE.

Tongue and groove seat and diaphragm for positive through flow shut off and diaphragm to body seal.

PVDF coated stainless steel spring.

Submergible option isolates all valve components from the external environment.

Benefits

High cycle life.

Lower replacement costs.

Less downtime.

Reduces effects of corrosive environments.

Valve remains functional while operating in wet or gaseous corrosive environments.

Specifications

Materials of Construction:

Wetted Surfaces - PFA, Modified PTFE

External Surfaces - PFA, PVDF

Other Materials - Viton Seals, PVDF coated stainless steel spring

Pressure Ranges:

Forward - 27" Hg vacuum (913 mbar) to 100 PSIG (7 bar)

Back - 27" Hg Vacuum (913 mbar) to 100 PSIG (7 bar)

Pressure ranges above are for operation at ambient temperatures. For use at higher temperatures consult Pressure/Temperature chart on page 3.

Temperature Ranges:

0° - 150° F (-17° - 66° C) Ambient

0° - 266° F (-17° - 130° C) Fluid

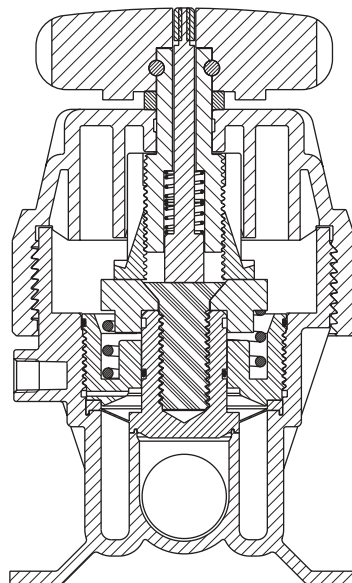

MV-12 1" Manual Valve

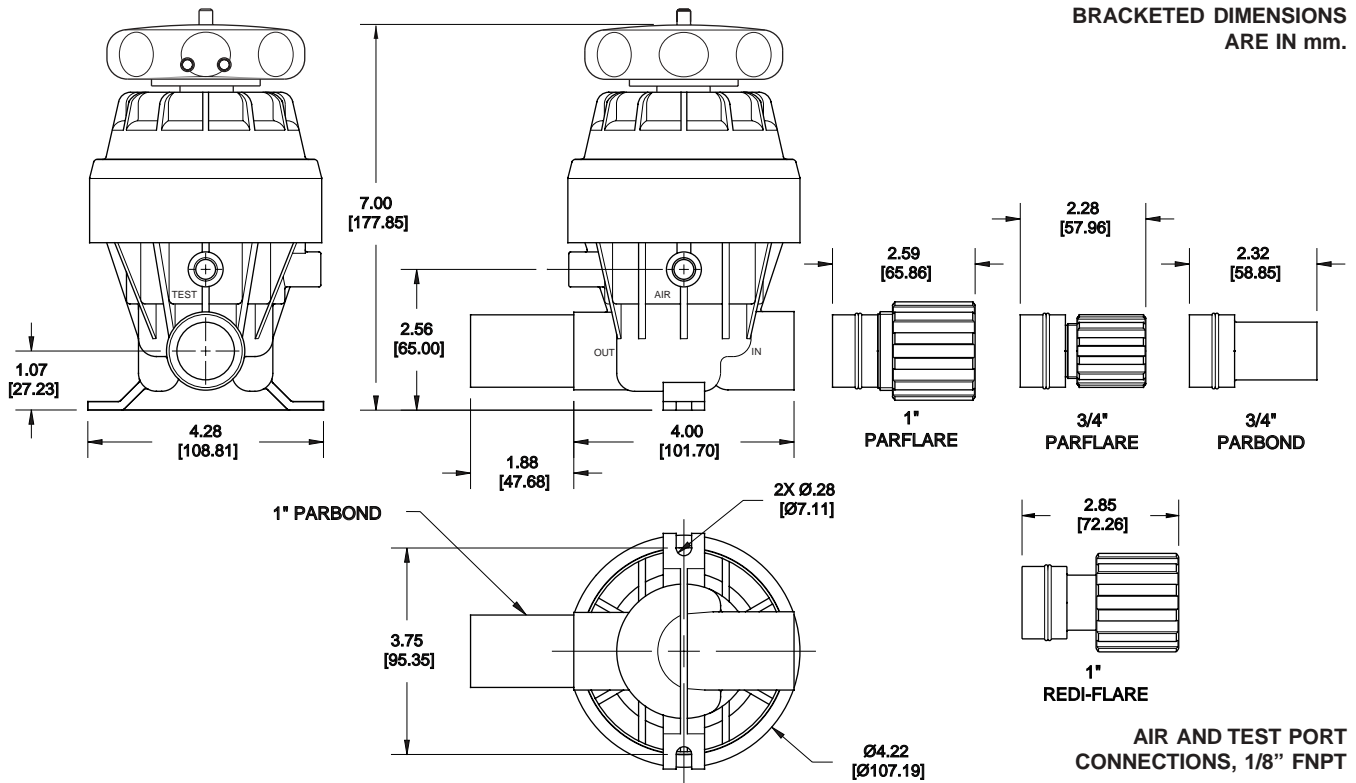

Model Number	Cv	Kv	Flow Configuration	Inlet Port	Outlet Port
MV-12-001	15.7	224.2	ON/OFF	1" Parbond	1" Parbond
MV-12-002	13.3	189.9	"	1" Parflare	1" Parflare
MV-12-003	9.6	142.8	"	3/4" Parbond	3/4" Parbond
MV-12-004	6.8	142.8	"	3/4" Parflare	3/4" Parflare

Above Parflare model numbers are supplied with PVDF nuts. For PFA nuts add -T to model number. For high temperature nut assemblies, add -HT. Consult factory for delivery and pricing. Please consult factory for other available configurations, custom assemblies or leak sensor assemblies.

PRESSURE DROP VS. FLOW RATE

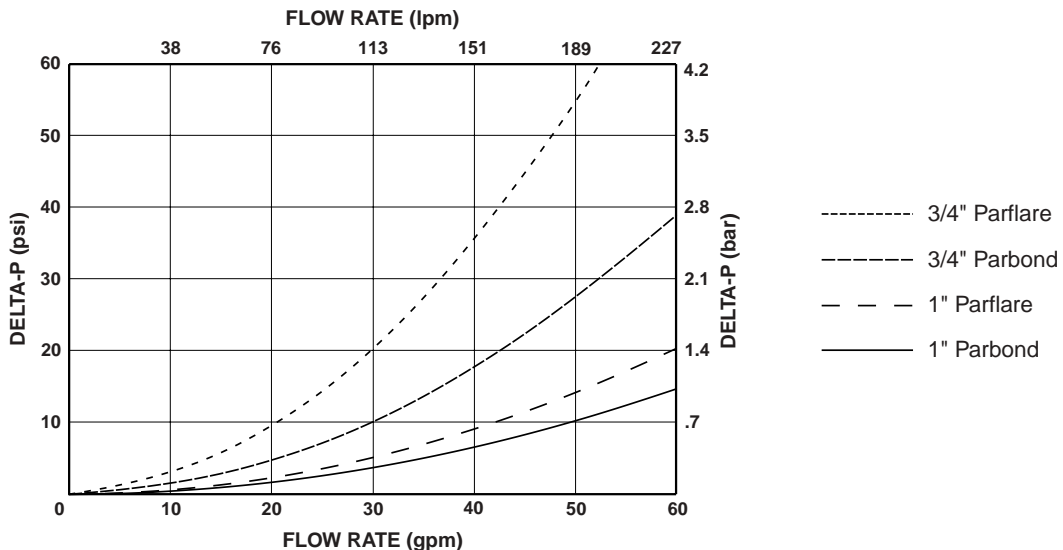

MV-13 Manual Needle Valve

Product Overview

The MV-13 Needle Valve is designed for high purity or aggressive chemical and gas applications. The design utilizes a molded high purity PFA body and stem as the only wetted components. The stem sealing area is precision machined for smooth, consistent flow. A PTFE ferrule assures a leak tight seal between stem and body. A PFA stem stop prevents removal of stem from body during operation. The MV-13 is available in straight through and angle configurations, several orifice sizes, and numerous end connections.

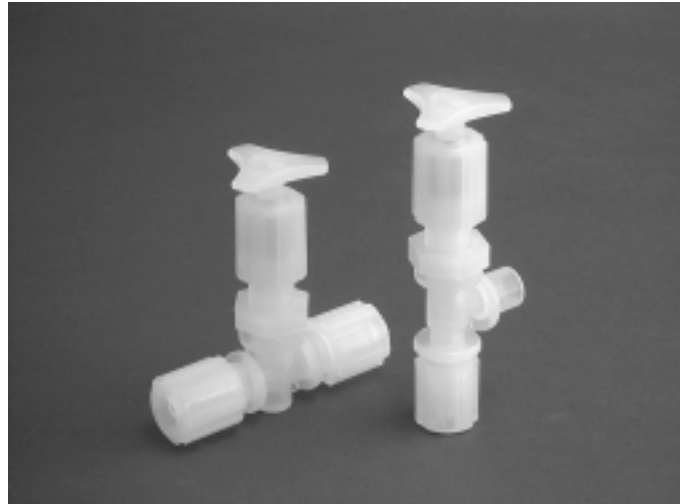

Features

One piece PFA stem/handle and bodies.

PFA stem stop.

Angle and straight through configurations, with numerous end configurations including Parflare available.

Benefits

High strength and corrosion resistance.

Safer operation.

Reduces connections, mounting space, and overall cost.

Specifications

Materials of Construction:

Wetted Surfaces - PFA, PTFE

External Surfaces - PFA, Reinforced ETFE gripper on Pargrip models, and PVDF Panel Nut

Pressure Ranges:

27" Hg vacuum (913 mbar) to 120 PSIG (8.3 bar)

Pressure range above is for operation at ambient temperatures. For use at higher temperatures consult Pressure/Temperature chart on page 3.

Temperature Ranges:

0° - 212° F (-17° - 100° C) Ambient

0° - 266° F (-17° - 130° C) Fluid

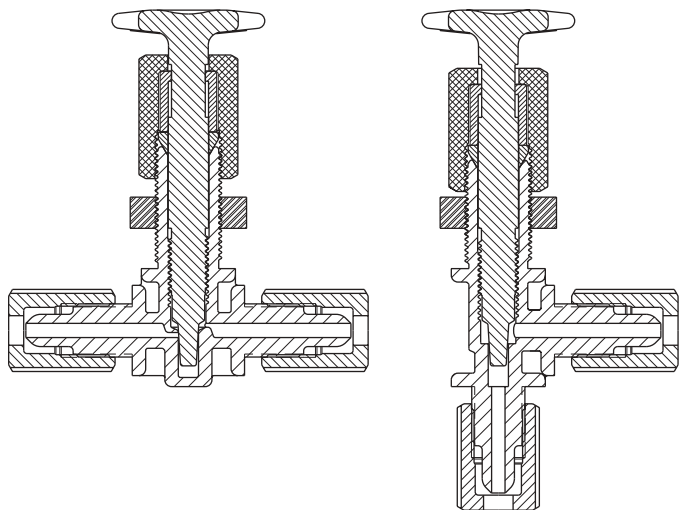

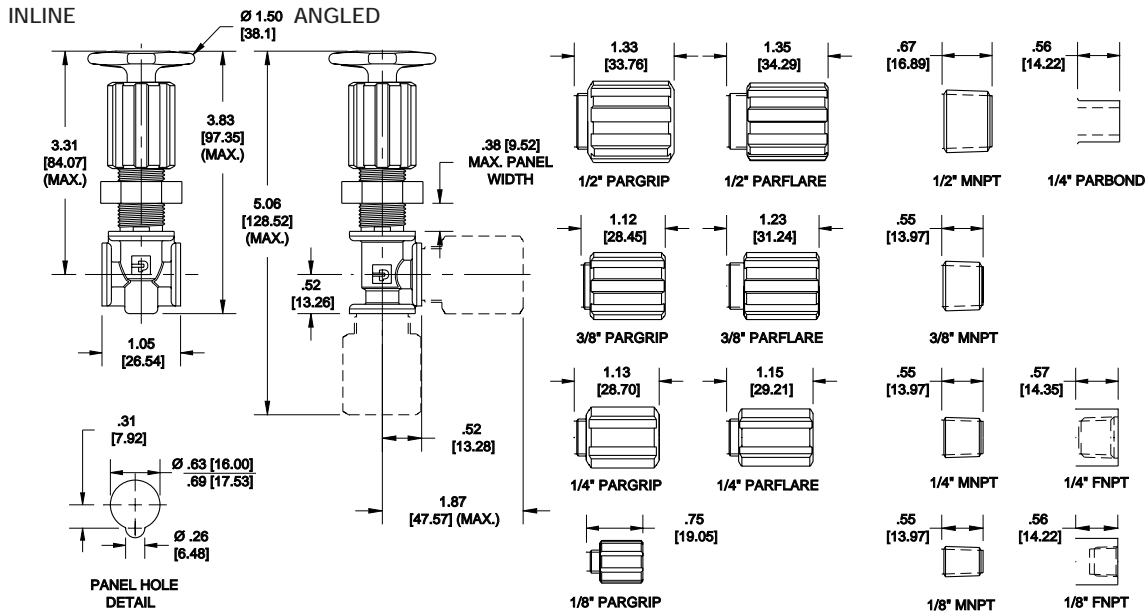

BRACKETED DIMENSIONS ARE IN mm.

For overall product dimensions, add the specific end connections from above to basic body dimensions.

Model Number	Orifice Size	Inlet / Outlet Port Configuration	Flow Configuration
MV-13-100	.063	1/8" Pargrip X 1/8" Pargrip	Straight
MV-13-104	.063	1/4" Parflare X 1/4" Parflare	"
MV-13-105	.063	1/4" MNPT X 1/4" Parflare	"
MV-13-106	.063	1/4" Parflare X 1/4" Parbond	"
MV-13-120	.125	1/4" Pargrip X 1/4" Pargrip	"
MV-13-124	.125	3/8" Parflare X 3/8" Parflare	"
MV-13-125	.125	1/2" Parflare X 1/2" Parflare	"
MV-13-126	.125	1/8" FNPT X 1/8" FNPT	"
MV-13-139	.125	3/8" Parflare X 1/4" FNPT	"
MV-13-163	.188	3/8" Pargrip X 3/8" Pargrip	"
MV-13-166	.188	1/2" Pargrip X 1/2" Pargrip	"
MV-13-170	.188	1/4" FNPT X 1/4" FNPT	"
MV-13-220	.125	1/4" MNPT X 1/4" Parflare	Angle
MV-13-221	.125	1/4" Parflare X 1/4" Parbond	"
MV-13-222	.125	1/4" Parflare X 1/4" Parflare	"
MV-13-225	.125	3/8" Parflare X 3/8" Parflare	"
MV-13-228	.125	3/8" Pargrip X 3/8" Pargrip	"

Above Parflare and Pargrip model numbers are supplied with PFA nuts. For high temperature nut assemblies, add -HT. Consult factory for delivery and pricing. Please consult factory for other available configurations or custom assemblies.

C_v / K_v vs. Turns

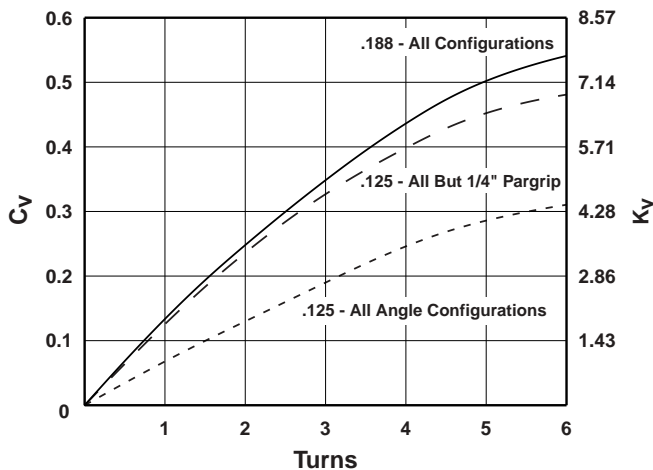

C_v / K_v vs. Turns

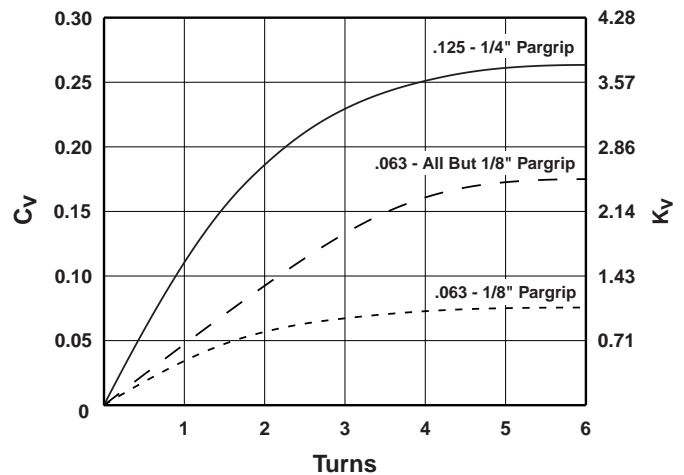

MV-14 Manual Stop Cock Valve

Product Overview

The MV-14 2 Way Stop Cock Valve is designed for use in high purity semiconductor applications. The design utilizes a molded high purity PFA body, and a machined PTFE stem. The press-fit stem assures a leak tight seal between it and the body during operation. Valve operates with a quick 90° turn operation and has a full 1/8" orifice.



Features

One piece precision machined stem and molded high purity PFA body.

All components made of chemical resistant materials.

Numerous end configurations, including Parflare available.

Benefits

Maintains system purity.

Suitable for use in corrosive environments.

Allows direct installation, minimizing additional connections, reducing cost.

Specifications

Materials of Construction:

Wetted Surfaces - PFA, PTFE
External Surfaces - PFA, PVDF

Pressure Range:

0 to 60 PSIG (4.1 bar)

Pressure ranges above are for operation at ambient temperature. For use at higher temperatures consult Pressure/Temperature chart on page 3.

Temperature Ranges:

0° - 150° F (-17° - 66° C) Ambient

0° - 266° F (-17° - 130° C) Fluid

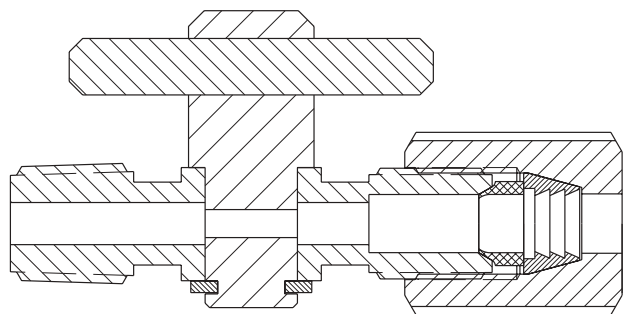

MV-14 Manual Stop Cock Valve

BRACKETED DIMENSIONS
ARE IN mm.

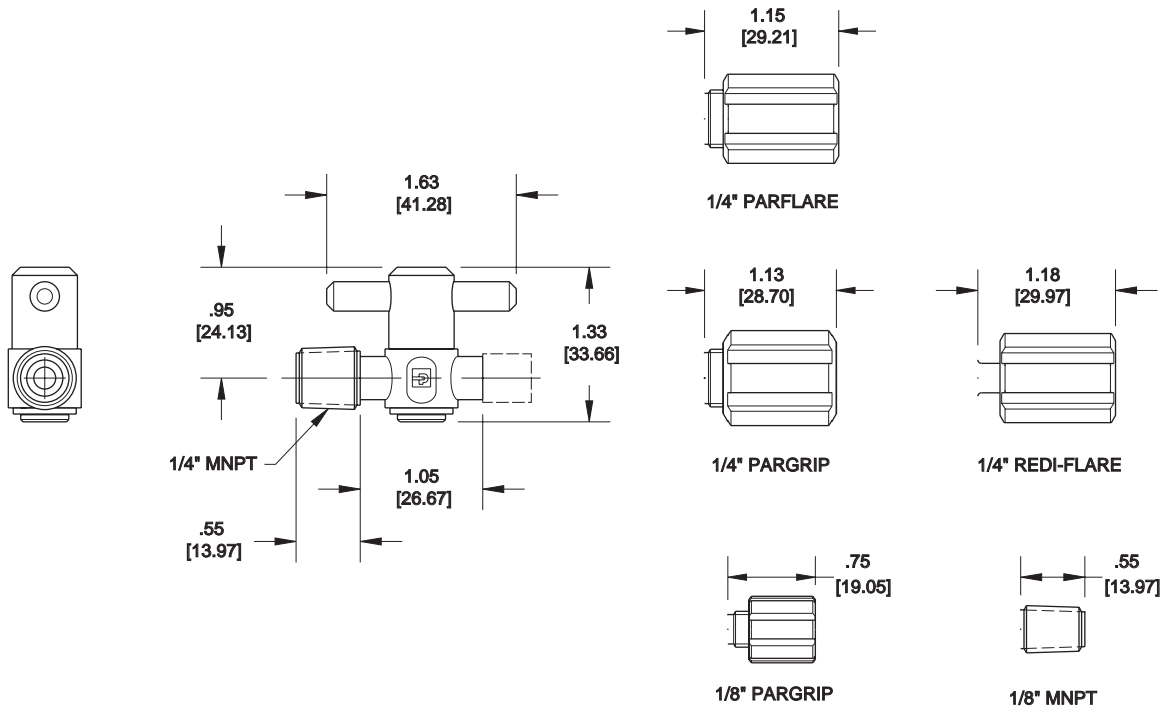

Model Number	Cv	Kv	Flow Config.	Inlet Port	Outlet Port
MV-14-003	.27	3.85	ON / OFF	1/4" Pargrip	1/4" Pargrip
MV-14-004	.27	3.85	*	1/4" Pargrip	1/8" MNPT
MV-14-005	.27	3.85	*	1/4" Pargrip	1/4" MNPT
MV-14-006	.27	3.85	*	1/4" MNPT	1/4" MNPT

Model Number	Cv	Kv	Flow Config.	Inlet Port	Outlet Port
MV-14-007	.27	3.85	ON / OFF	1/4" Parflare	1/4" Parflare
MV-14-015	.27	3.85	*	1/4" Parflare	1/4" MNPT
MV-14-016	.27	3.85	*	1/4" Parflare	1/4" Redi-flare
MV-14-018	.27	3.85	*	1/8" Pargrip	1/8" Pargrip

Above Pargrip model numbers are supplied with PFA nuts, and Parflare models are supplied with PVDF nuts. For PFA nuts add -T to model number. Please consult factory for other available configurations or custom assemblies.

PRESSURE DROP VS. FLOW RATE

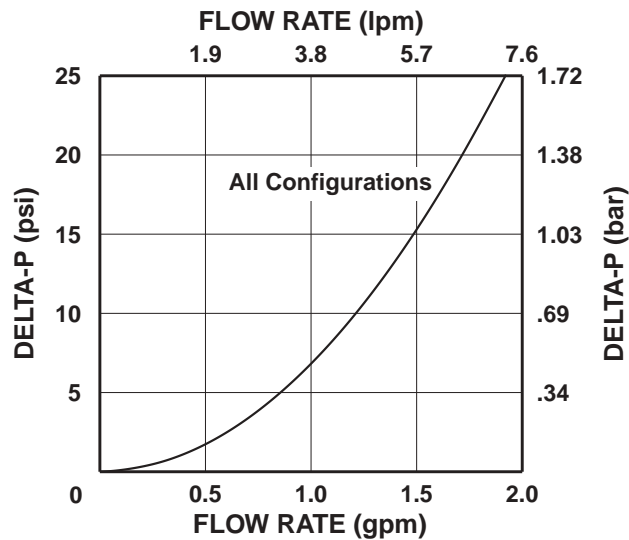

PV-1 Miniature Pneumatic Valve

Product Overview

The PV-1 Miniature Diaphragm Valve is designed for use in high purity semiconductor applications, and is also ideally suited for ultra-pure water and aggressive chemical systems. The design utilizes a machined modified PTFE body, seat and diaphragm ensuring excellent flexibility and long life. The valve is available in 2 and 3 way configurations. It is ideal for low flow and small dose injection applications.



Features

Precision machined diaphragm manufactured from the latest technology modified PTFE. Provides over five times the flexural life as compared to conventional PTFE. Tongue and groove seal for positive diaphragm to body seal.

Compact design actuator works on as little as 20 psi.

Benefits

High cycle life.

Lower replacement costs.

Less downtime.

Isolates media from actuator.

Ease of installation and maintenance.

Specifications

Materials of Construction:

Wetted Surfaces - PTFE, Modified PTFE
Non Wetted Surfaces - Anodized Aluminum, SS, Nitrile.

Pressure Ranges:

25" HG vacuum (846 mbar) to 20 PSIG (1.4 bar)
Actuator Pressure: 20 to 120 PSIG (1.4 to 8.3 bar)

Pressure ranges above are for operation at ambient temperature. For use at higher temperatures consult Pressure/Temperature chart on page 3.

Temperature Ranges:

-60° - 212° F (-51° - 100° C) Ambient
-60° - 400° F (-51° - 204° C) Fluid

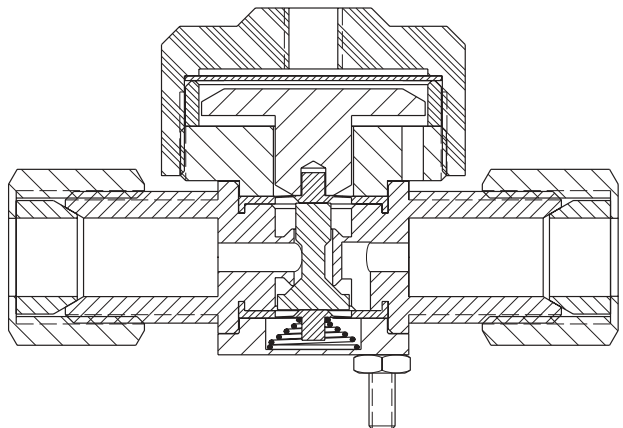

PV-1 Miniature Pneumatic Valve

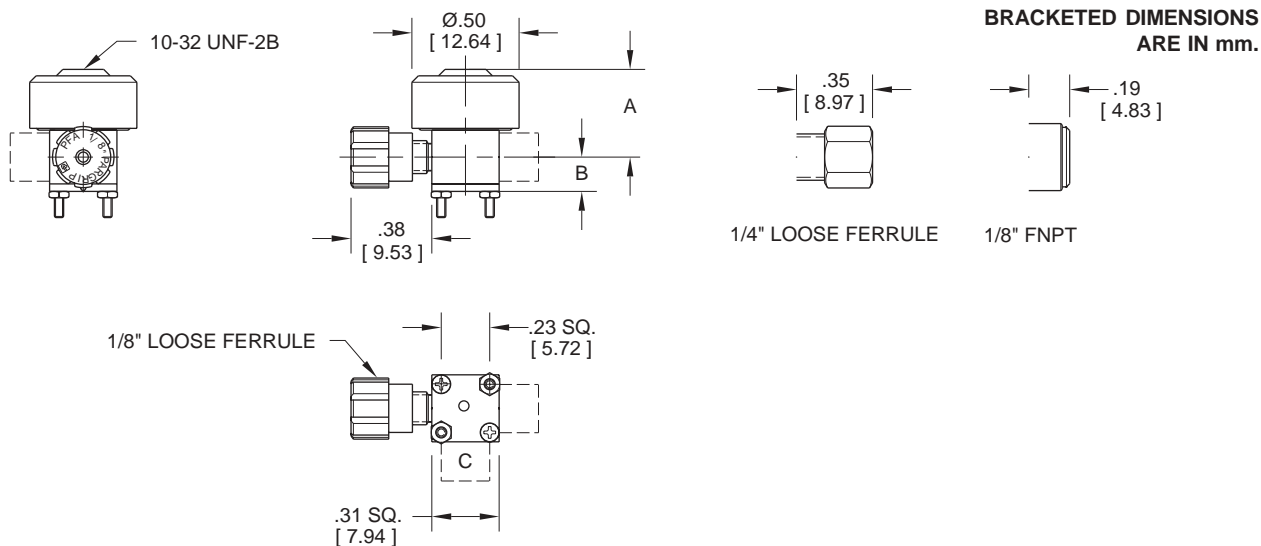

	DIMENSIONS (in.)			DIMENSIONS (mm.)		
	A	B	C	A	B	C
PV-1-2134	.82	.32	N/A	20.83	8.13	N/A
PV-1-2138	.82	.32	N/A	20.83	8.13	N/A
PV-1-2334	.82	.32	1/8" LOOSE FERRULE	20.83	8.13	1/8" LOOSE FERRULE
PV-1-1134	.82	.38	N/A	20.83	9.65	N/A
PV-1-1324	.82	.38	1/8" FNPT	20.83	9.65	1/8" FNPT
PV-1-1334	.82	.38	1/8" FNPT	20.83	9.65	1/8" FNPT

Model Number	Cv	Kv	Flow Config.	Orifice Size	Port Configuration
PV-1-2134	.08	1.1	NC	.094	1/8" Loose Ferrule
PV-1-2138	.08	1.1	NC	.094	1/4" Loose Ferrule
PV-1-2334	.08	1.1	3 WAY	.094	1/8" Loose Ferrule

Model Number	Cv	Kv	Flow Config.	Orifice Size	Port Configuration
PV-1-1134	.08	1.1	NC	.094	1/8" FNPT
PV-1-1324	.06	.9	3 WAY	.063	1/8" FNPT
PV-1-1334	.08	1.1	"	.094	1/8" FNPT

PRESSURE DROP VS. FLOW RATE

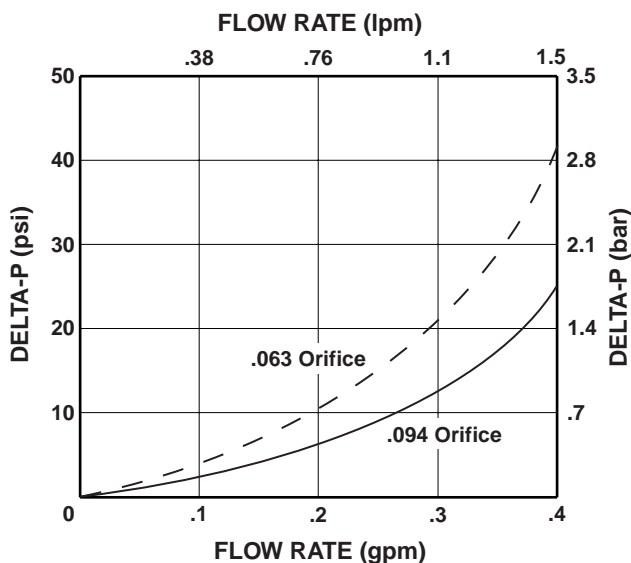

PV-10 1/4" Pneumatic Valve

Product Overview

The PV-10 Diaphragm Valve is designed for use in high purity semiconductor applications. It is also ideally suited for ultra-pure water and aggressive chemical or gas applications. The design utilizes a molded high purity PFA body with precision machined areas. A one piece machined modified PTFE diaphragm is also utilized for excellent flexibility and life. A full 1/4" orifice provides maximum flow capability in a compact package.



Features

One piece precision machined diaphragms manufactured from the latest technology modified PTFE.

Provides over five times the flexural life as compared to conventional PTFE.

Tongue and groove seat and diaphragm for positive through flow shut off and diaphragm to body seal.

PVDF coated stainless steel spring.

Benefits

High cycle life.

Lower replacement costs.

Less downtime.

Reduces effects of corrosive environments.

Specifications

Materials of Construction:

Wetted Surfaces - PFA, Modified PTFE

External Surfaces - PFA, PVDF, 18-8 stainless steel.

Other Materials - Viton seals, PVDF coated stainless steel spring.

Pressure Ranges:

Forward - 27" Hg vacuum (913 mbar) to 80 PSIG (5.5 bar)

Back - 27" Hg vacuum (913 mbar) to 80 PSIG (5.5 bar)

Actuator - 20 (1.4 bar) to 120 PSIG (8.2 bar)

Pressure ranges above are for operation at ambient temperature. For use at higher temperatures consult Pressure/Temperature chart on page 3.

Temperature Ranges:

0° - 150° F (-17° - 66° C) Ambient

0° - 266° F (-17° - 130° C) Fluid

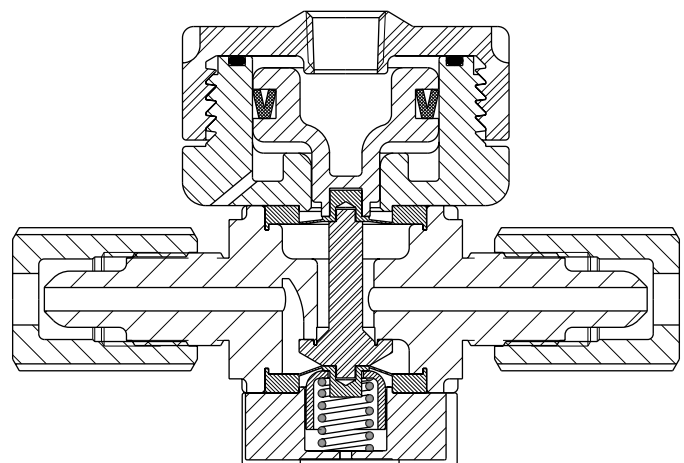

Normally Closed shown

PV-10 1/4" Pneumatic Valve

BRACKETED DIMENSIONS ARE IN mm.

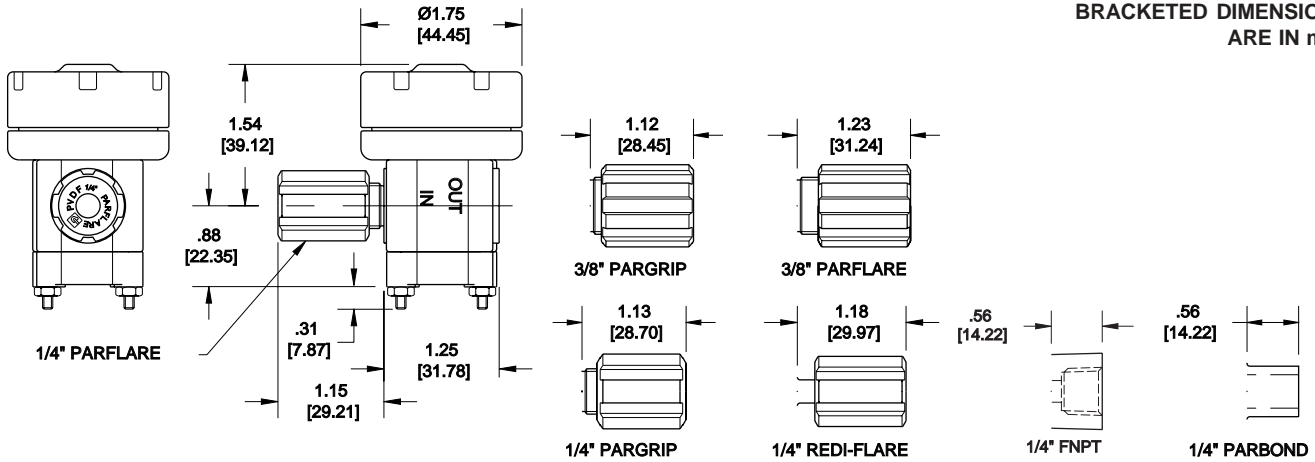

AIR PORT CONNECTION, 1/8" FNPT

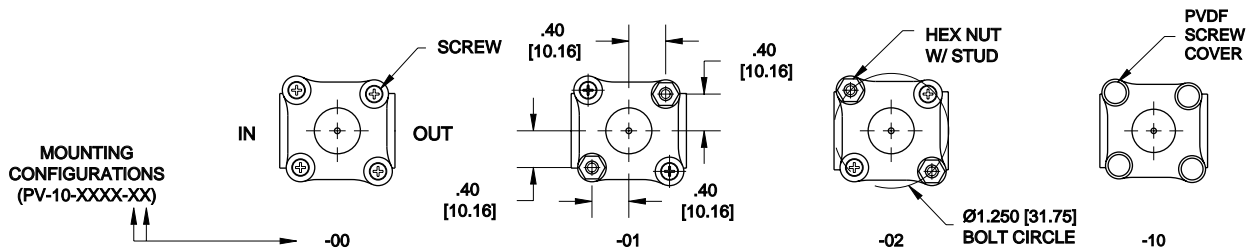

Model Number	Cv	Kv	Flow Config.	Inlet Port	Outlet Port
PV-10-1144-XX	.60	8.6	N C	1/4" FNPT	1/4" FNPT
PV-10-1244-XX	.60	8.6	N O	1/4" FNPT	1/4" FNPT
PV-10-2134-XX	.24	3.4	N C	1/4" Pargrip	1/4" Pargrip
PV-10-2146-XX	.62	8.8	N C	3/8" Pargrip	3/8" Pargrip
PV-10-2234-XX	.24	3.4	N O	1/4" Pargrip	1/4" Pargrip
PV-10-2246-XX	.62	8.8	N O	3/8" Pargrip	3/8" Pargrip
PV-10-6124-XX	.20	2.8	N C	1/4" Parflare	1/4" Parflare
PV-10-6124-XX-20	.20	2.8	N C	1/4" Redi-flare	1/4" Parflare
PV-10-6124-XX-21	.20	2.8	N C	1/4" Parflare	1/4" Redi-flare
PV-10-6146-XX	.62	8.8	N C	3/8" Parflare	3/8" Parflare

Model Number	Cv	Kv	Flow Config.	Inlet Port	Outlet Port
PV-10-6146-XX-20	.62	8.8	N C	3/8" Redi-flare	3/8" Parflare
PV-10-6146-XX-21	.62	8.8	N C	3/8" Parflare	3/8" Redi-flare
PV-10-6224-XX	.20	2.8	N O	1/4" Parflare	1/4" Parflare
PV-10-6224-XX-20	.20	2.8	N O	1/4" Red- flare	1/4" Parflare
PV-10-6224-XX-21	.20	2.8	N O	1/4" Parflare	1/4" Redi-flare
PV-10-6246-XX	.62	8.8	N O	3/8" Parflare	3/8" Parflare
PV-10-6246-XX-20	.62	8.8	N O	3/8" Redi-flare	3/8" Parflare
PV-10-6246-XX-21	.62	8.8	N O	3/8" Parflare	3/8" Redi-flare
PV-10-7144-XX	.62	8.8	N C	1/4" Parbond	1/4" Parbond
PV-10-7244-XX	.62	8.8	N O	1/4" Parbond	1/4" Parbond

Above Pargrip model numbers are supplied with PFA nuts. Parflare models are supplied with PVDF nuts. For PFA nuts add -T as the final suffix to the model number (i.e. PV-10-6124-02-T). Please consult factory for other available configurations, custom assemblies or flow position sensor assemblies.

PRESSURE DROP VS. FLOW RATE

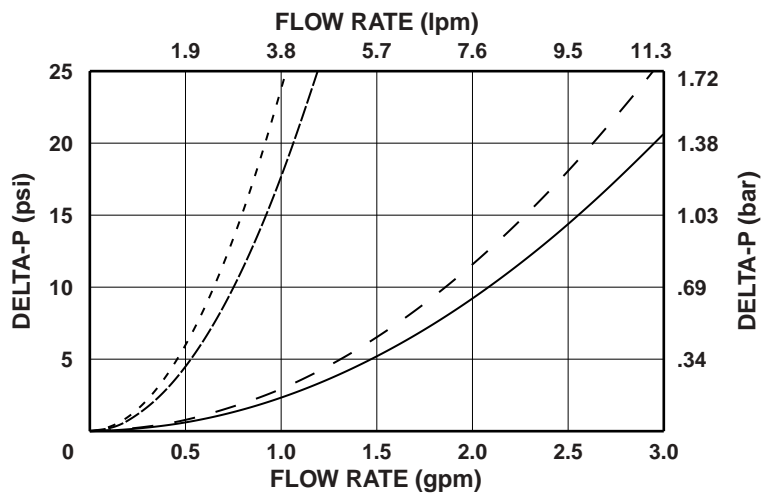

PV-10 1/4" Pneumatic Valve

Product Overview

The PV-10 3 Way Diaphragm Valve is designed for use in high purity semiconductor applications. It is also ideally suited for ultra-pure water and aggressive chemical or gas applications. The design utilizes a molded high purity PFA body with precision machined areas. One piece machined modified PTFE diaphragms are also utilized for excellent flexibility and life. A full 1/4" orifice provides maximum flow capability in a compact package.



Features

One piece precision machined diaphragms manufactured from the latest technology modified PTFE.

Provides over five times the flexural life as compared to conventional PTFE.

Tongue and groove seat and diaphragm for positive through flow shut off and diaphragm to body seal.

PVDF coated stainless steel springs.

Benefits

High cycle life.

Lower replacement costs.

Less downtime.

Reduces effects of corrosive environments.

Specifications

Materials of Construction:

Wetted Surfaces - PFA, Modified PTFE

External Surfaces - PFA, PVDF, 18-8 stainless steel

Other Materials - Viton seals, PVDF coated stainless spring.

Pressure Ranges:

Forward - 27" Hg vacuum (913 mbar) to 80 PSIG (5.5 bar)

Back - 27" Hg vacuum (913 mbar) to 80 PSIG (5.5 bar)

Actuator - 20 (1.4 bar) to 120 PSIG (8.2 bar).

Pressure ranges above are for operation at ambient temperature. For use at higher temperatures consult Pressure/Temperature chart on page 3.

Temperature Ranges:

0° - 150° F (-17° - 66° C) Ambient

0° - 266° F (-17° - 130° C) Fluid

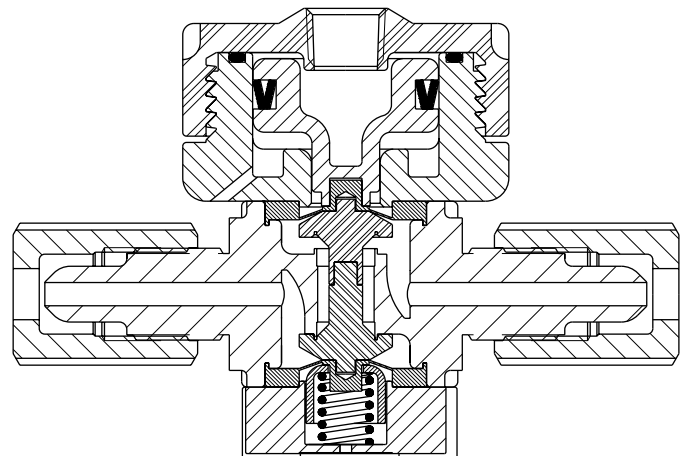

PV-10 1/4" Pneumatic Valve

BRACKETED DIMENSIONS
ARE IN mm.

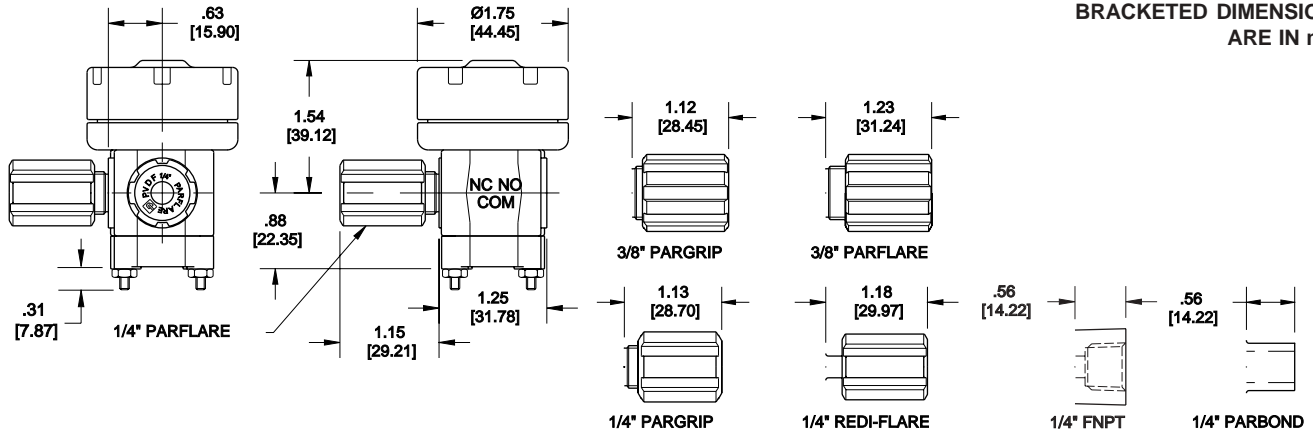

AIR PORT CONNECTION, 1/8" FNPT

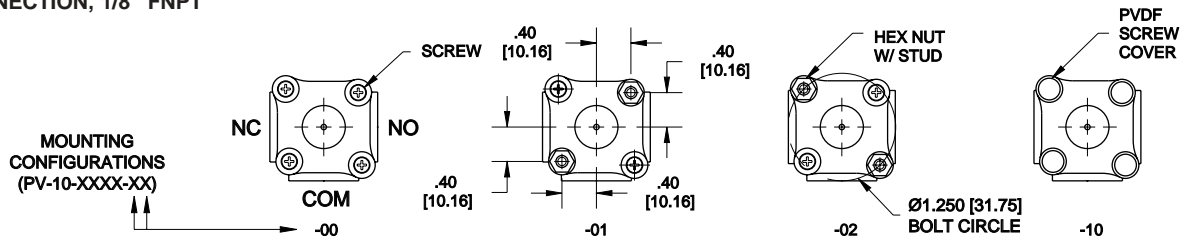

Model Number	Cv	Kv	Flow Configuration	Port Configuration
PV-10-1344-XX	.60	8.6	3 WAY	1/4" FNPT
PV-10-2324-XX	.20	2.9	"	1/4" Pargrip
PV-10-2346-XX	.62	8.8	"	3/8" Pargrip
PV-10-6324-XX	.20	2.9	"	1/4" Parflare
PV-10-6346-XX	.62	8.8	"	3/8" Parflare
PV-10-7344-XX	.62	8.8	"	1/4" Parbond

Above Pargrip model numbers are supplied with PFA nuts. Parflare models are supplied with PVDF nuts. For PFA nuts add -T as the final suffix to the model number (i.e. PV-10-6324-02-T). Please consult factory for other available configurations, custom assemblies or flow position sensor assemblies.

PRESSURE DROP VS. FLOW RATE

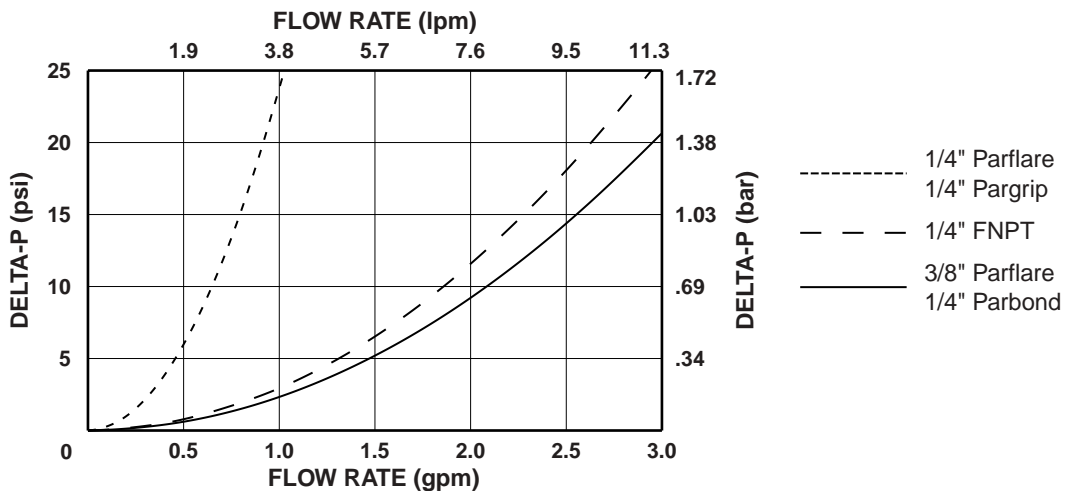

PV-11 1/2" Pneumatic Valve

Product Overview

The PV-11 Diaphragm Valve is designed for use in high purity semiconductor applications. It is also ideally suited for ultra-pure water and aggressive chemical or gas applications. The design utilizes a molded high purity PFA body with precision machined areas. A one piece machined modified PTFE diaphragm is also utilized for excellent flexibility and life. A full 1/2" orifice provides maximum flow capability in a compact package.



Features

One piece precision machined diaphragm manufactured from the latest technology modified PTFE.

Provides over five times the flexural life as compared to conventional PTFE.

Tongue and groove seat and diaphragm for positive through flow shut off and diaphragm to body seal.

PVDF coated stainless steel spring.

Submersible option isolates all valve components from the external environment.

Benefits

High cycle life.

Lower replacement costs.

Less downtime.

Reduces effects of corrosive environments.

Valve remains functional while operating in wet or gaseous corrosive environments.

Specifications

Materials of Construction:

Wetted Surfaces - PFA, Modified PTFE

External Surfaces - PFA, PVDF

Other Materials - Viton Seals, PVDF coated stainless spring.

Pressure Ranges:

Forward - 27" Hg Vacuum (913 mbar) to 100 PSIG (7 bar)

Back - 27" Hg vacuum (913 mbar) to 20 PSIG (1.4 bar) with 100 PSIG (7 bar) inlet pressure, 50 PSIG (3.5 bar) with 50 PSIG (3.5 bar) inlet pressure, 70 PSIG (4.9 bar) with 0 PSIG (0 bar) inlet pressure

Actuator - 60 (4.2 bar) to 100 PSIG (7 bar)

Pressure ranges above are for operation at ambient temperature. For use at higher temperatures consult Pressure/Temperature chart on page 3.

Temperature Ranges:

0° - 150° F (-17° - 66° C) Ambient

0° - 266° F (-17° - 130° C) Fluid

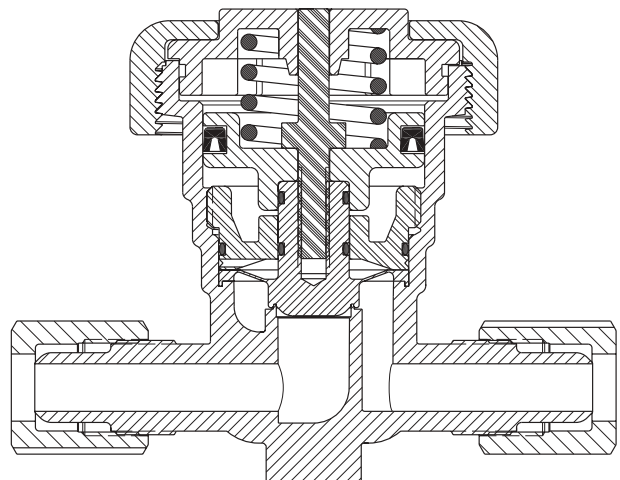

Normally Closed shown

PV-11 1/2" Pneumatic Valve

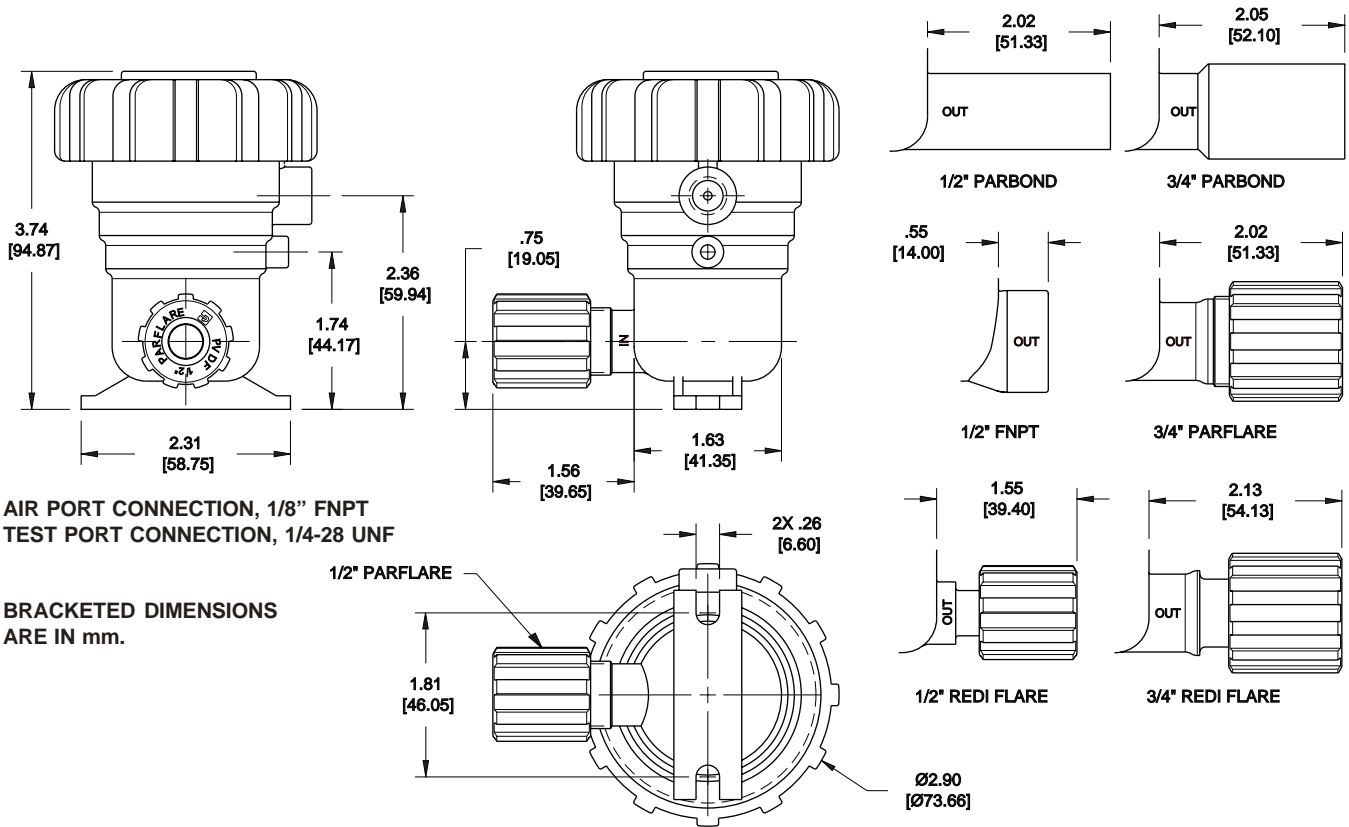

Model Number	Cv	Kv	Flow Config.	Inlet Port	Outlet Port
PV-11-001	2.3	32.8	N C	1/2" Parflare	1/2" Parflare
PV-11-002	3.7	52.8	N C	3/4" Parflare	3/4" Parflare
PV-11-003	3.7	52.8	N C	1/2" Parbond	1/2" Parbond
PV-11-004	3.7	52.8	N C	3/4" Parbond	3/4" Parbond
PV-11-005	3.7	52.8	N C	1/2" FNPT	1/2" FNPT
PV-11-008	2.3	32.8	N C	1/2" Redi-flare	1/2" Redi-flare
PV-11-008-01	2.3	32.8	N C	1/2" Redi-flare	1/2" Parflare
PV-11-009	3.7	52.8	N C	3/4" Redi-flare	3/4" Redi-flare
PV-11-009-01	3.7	52.8	N C	3/4" Redi-flare	3/4" Parflare

Model Number	Cv	Kv	Flow Config.	Inlet Port	Outlet Port
PV-11-011	2.3	32.8	N O	1/2" Parflare	1/2" Parflare
PV-11-012	3.7	52.8	N O	3/4" Parflare	3/4" Parflare
PV-11-013	3.7	52.8	N O	1/2" Parbond	1/2" Parbond
PV-11-014	3.7	52.8	N O	3/4" Parbond	3/4" Parbond
PV-11-015	3.7	52.8	N O	1/2" FNPT	1/2" FNPT
PV-11-018	2.3	32.8	N O	1/2" Redi-flare	1/2" Redi-flare
PV-11-018-01	2.3	32.8	N O	1/2" Redi-flare	1/2" Parflare
PV-11-019	3.7	52.8	N O	3/4" Redi-flare	3/4" Redi-flare
PV-11-019-01	3.7	52.8	N O	3/4" Redi-flare	3/4" Parflare

Above Parflare model numbers are supplied with PVDF nuts. For PFA nuts add -T to model number. For high temperature nut assemblies, add -HT. Consult factory for delivery and pricing. Please consult factory for other available configurations, custom assemblies or flow position and leak sensor assemblies.

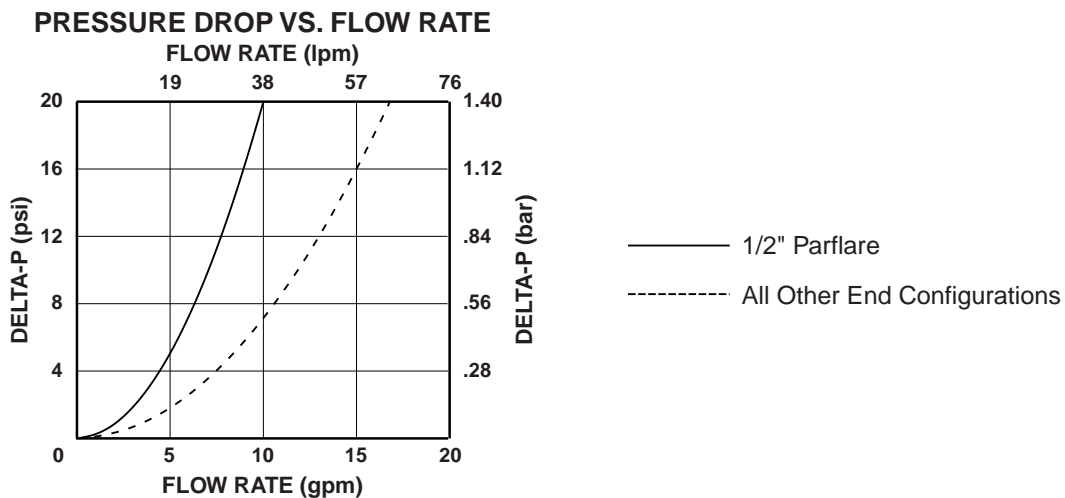

PV-11 1/2" Pneumatic Valve

Product Overview

The PV-11 3 Way Diaphragm Valve is designed for use in high purity semiconductor applications. It is also ideally suited for ultra-pure water and aggressive chemical or gas applications. The design utilizes a molded high purity PFA body with precision machined areas. One piece machined modified PTFE diaphragms are also utilized for excellent flexibility and life. A full 1/2" orifice provides maximum flow capability in a compact package.



Features

One piece precision machined diaphragms manufactured from the latest technology modified PTFE.

Provides over five times the flexural life as compared to conventional PTFE.

Tongue and groove seat and diaphragm for positive through flow shut off and diaphragm to body seal.

PVDF coated stainless steel springs.

Submersible option isolates all valve components from the external environment.

Multi-position mounting base.

Benefits

High cycle life.

Lower replacement costs.

Less downtime.

Reduces effects of corrosive environments.

Valve remains functional while operating in wet or gaseous corrosive environments.

Allows for more mounting flexibility and connector fitting reduction.

Specifications

Materials of Construction:

Wetted Surfaces - PFA, Modified PTFE

External Surfaces - PFA, PVDF

Other Materials - Viton Seals, PVDF coated stainless spring.

Pressure Ranges:

From COM Port to N.O. or N.O. Port to COM Port - 27" Hg vacuum (913 mbar) to 80 PSIG (5.5 bar).

From COM Port to N.C. Port - 27" Hg vacuum (913 mbar) to 80 PSIG (5.5 bar) with 20 PSIG (1.4 bar) maximum back pressure.

From N.C. Port to COM Port - 27" Hg vacuum (913 mbar) to 80 PSIG (5.5 bar) with 50 PSIG (3.4 bar) maximum back pressure.

Actuator - 60 (4.2 bar) to 100 PSIG (7 bar).

Pressure ranges above are for operation at ambient temperature. For use at higher temperatures consult Pressure/Temperature chart on page 3.

Temperature Ranges:

0° - 150° F (-17° - 66° C) Ambient

0° - 266° F (-17° - 130° C) Fluid

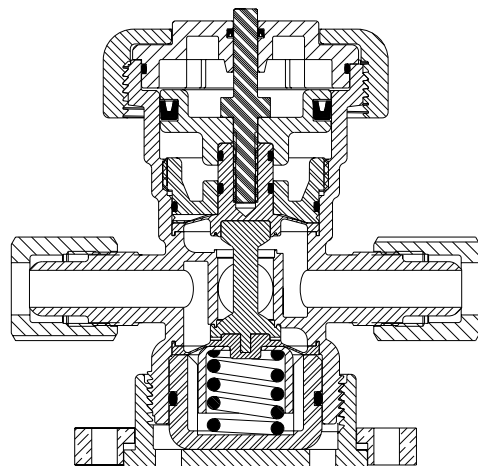

PV-11 1/2" Pneumatic Valve

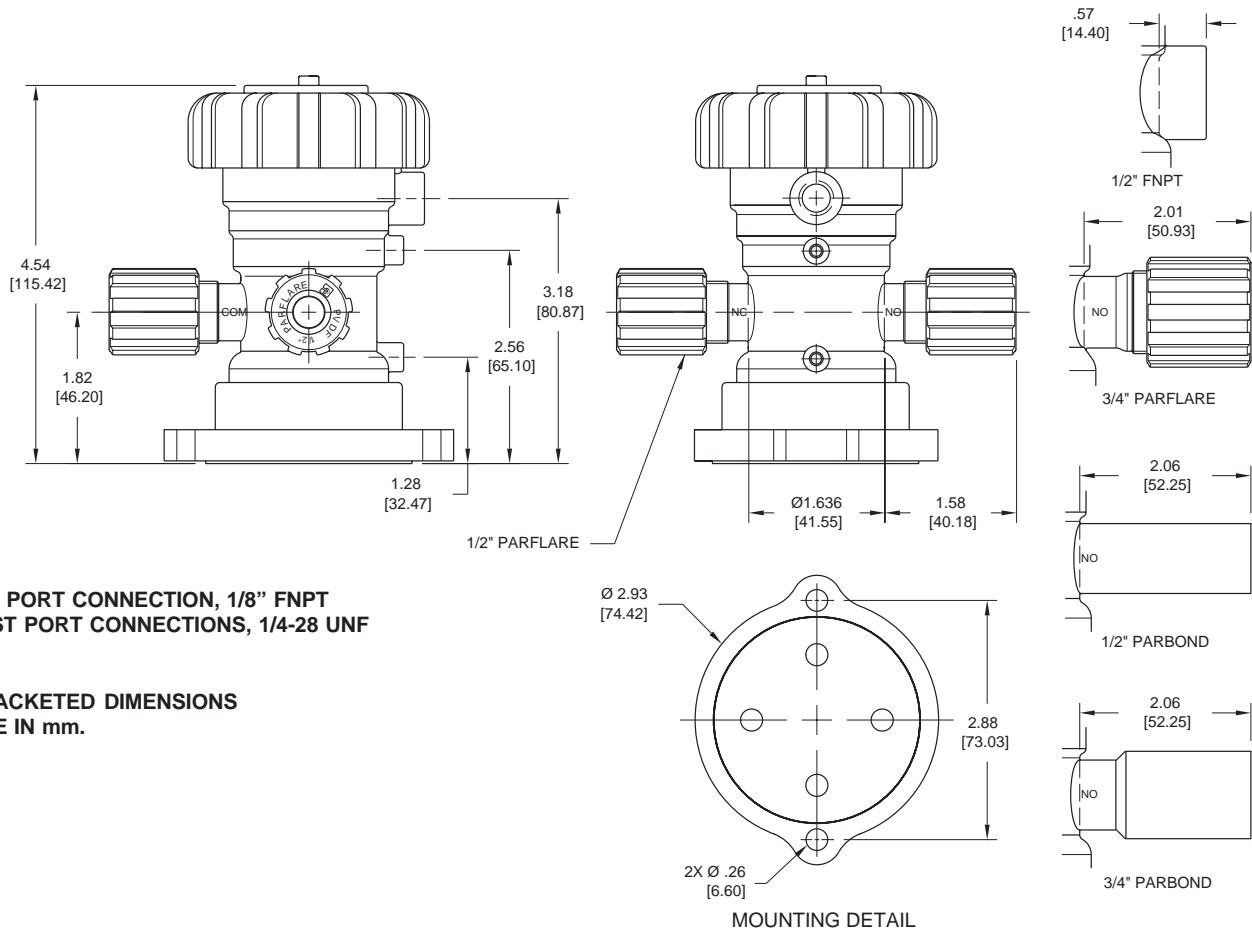

Model Number	Cv	Kv	Flow Configuration	Port Configuration
PV-11-021	1.9	27.1	3 WAY	1/2" Parflare
PV-11-022	2.8	40.0	"	3/4" Parflare
PV-11-023	2.8	40.0	"	1/2" Parbond
PV-11-024	2.8	40.0	"	3/4" Parbond
PV-11-025	2.8	40.0	"	1/2" FNPT

Above Parflare model numbers are supplied with PVDF nuts. For PFA nuts add -T to model number. For high temperature nut assemblies, add -HT. Consult factory for delivery and pricing. Please consult factory for other available configurations, custom assemblies or flow position and leak sensor assemblies.

PRESSURE DROP VS. FLOW RATE

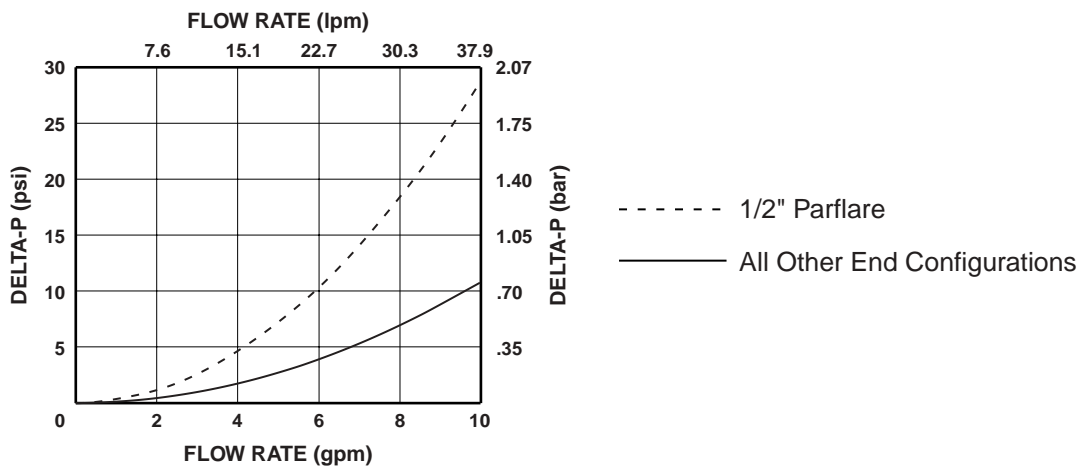

PV-11 1/2" Pneumatic Valve

Product Overview

The PV-11 Adjustable Bypass Valve is designed for use in ultra-pure water applications. The design utilizes a molded high purity PFA body with precision machined seats. A machined modified PTFE diaphragm is also utilized for excellent flexibility and life. The integral bypass valve prevents the stagnation and deadheading of media in an PV-10 1/4" Pneumatic Valve ultra-pure water system.



Features

Precision machined diaphragm manufactured from the latest technology modified PTFE. Provides over five times the flexural life as compared to conventional PTFE. Tongue and groove seat and diaphragm for positive through flow shut off and diaphragm to body seal.

PVDF coated stainless steel spring.

Bypass integral to valve body to prevent stagnation of ultra-pure water.

Modified flow configurations with numerous end connections including Parflare available.

Benefits

High cycle life.

Lower replacement costs.

Less downtime.

Reduces effects of corrosive environment.

Prevents contamination of media.

Reduces connections, mounting space, and overall cost.

Specifications

Materials of Construction:

Wetted Surfaces - PFA, Modified PTFE

External Surfaces - PFA, PVDF

Other Materials - Viton Seals, PVDF coated stainless spring.

Pressure Ranges:

From COM Port to N.O. or N.O. Port to COM Port - 27" Hg vacuum (913 mbar) to 80 PSIG (5.5 bar).

From COM Port to N.C. Port - 27" Hg vacuum (913 mbar) to 80 PSIG (5.5 bar) with 20 PSIG (1.4 bar) maximum back pressure.

From N.C. Port to COM Port - 27" Hg vacuum (913 mbar) to 80 PSIG (5.5 bar) with 50 PSIG (3.4 bar) maximum back pressure.

Actuator - 60 (4.2 bar) to 100 PSIG (7 bar).

Pressure ranges above are for operation at ambient temperature. For use at higher temperatures consult Pressure/Temperature chart on page 3.

Temperature Ranges:

0° - 150° F (-17° - 66° C) Ambient

0° - 266° F (-17° - 130° C) Fluid

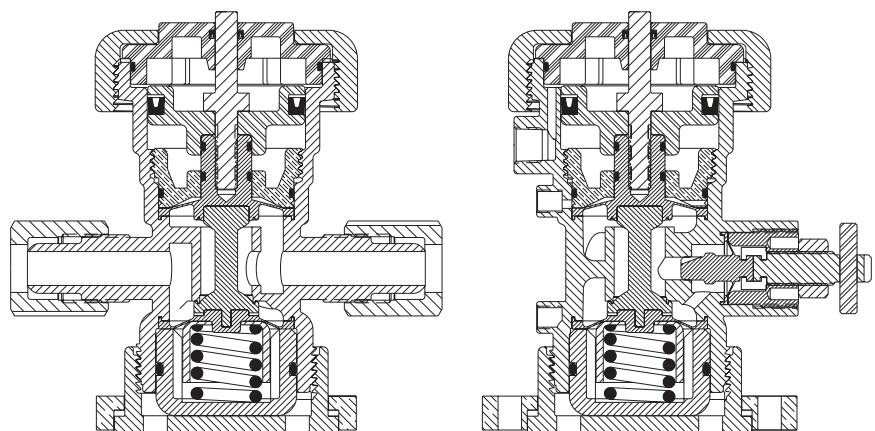

PV-11 1/2" Pneumatic Valve

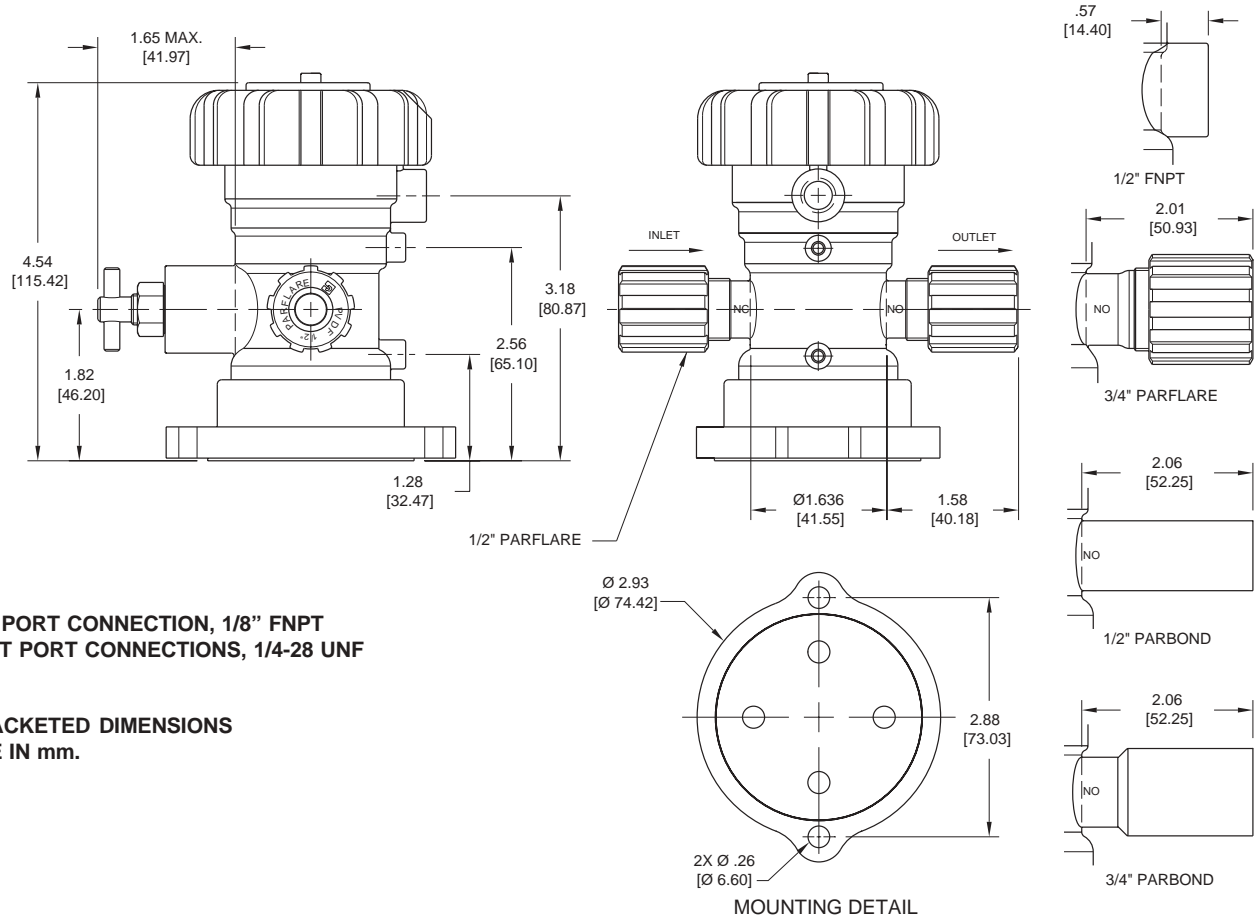

AIR PORT CONNECTION, 1/8" FNPT
TEST PORT CONNECTIONS, 1/4-28 UNF

BRACKETED DIMENSIONS
ARE IN mm.

Model Number	Cv	Kv	Flow Configuration	Inlet Port	Outlet Port
PV-11-301	1.9	27.1	NC	1/2" Parflare	1/2" Parflare
PV-11-302	2.8	40.0	"	3/4" Parflare	3/4" Parflare
PV-11-303	2.8	40.0	"	1/2" Parbond	1/2" Parbond
PV-11-304	2.8	40.0	"	3/4" Parbond	3/4" Parbond
PV-11-305	2.8	40.0	"	1/2" FNPT	1/2" FNPT

Above Parflare model numbers are supplied with PVDF nuts. For PFA nuts add -T to model number. For high temperature nut assemblies, add -HT. Consult factory for delivery and pricing. Please consult factory for other available configurations, custom assemblies or flow position and leak sensor assemblies.

PRESSURE DROP VS. FLOW RATE

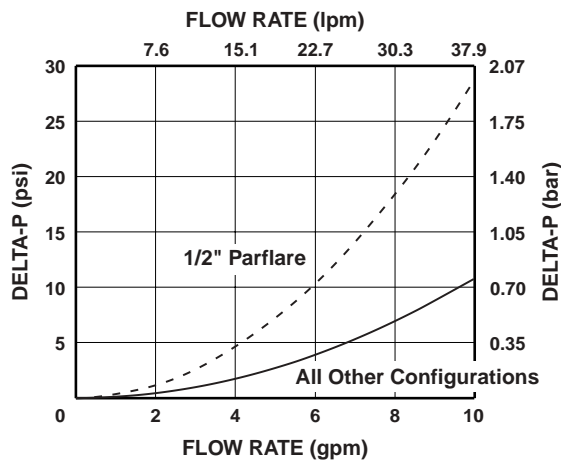

Cv / Kv vs. Turns for Bypass Port

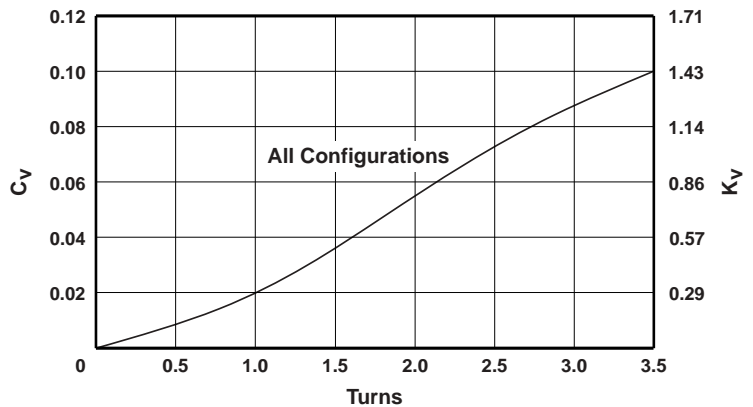

PV-12 1" Pneumatic Valve

Product Overview

The PV-12 Diaphragm Valve is designed for use in high purity semiconductor applications, and is also ideally suited for ultra-pure water and aggressive chemical or gas applications. The design utilizes a molded high purity PFA body with precision machined seat and diaphragm sealing areas. A one piece machined modified PTFE diaphragm is also utilized for excellent flexibility and life. A full 1" orifice provides maximum flow capability in a compact package.



Features

One piece precision machined diaphragm manufactured from the latest technology modified PTFE.

Provides over five times the flexural life as compared to conventional PTFE.

Tongue and groove seat and diaphragm for positive through flow shut off and diaphragm to body seal.

PVDF coated stainless steel spring.

Submersible option isolates all valve components from the external environment.

Benefits

High cycle life.

Lower replacement costs.

Less downtime.

Reduces effects of corrosive environments.

Valve remains functional while operating in wet or gaseous corrosive environments.

Specifications

Materials of Construction:

Wetted Surfaces - PFA, Modified PTFE

External Surfaces - PFA, PVDF

Other Materials - Viton Seals, PVDF coated stainless steel spring.

Pressure Ranges:

Forward - 27" Hg vacuum (913 mbar) to 100 PSIG (7 bar)

Back - 27" Hg vacuum (913 mbar) to 80 PSIG (5.5 bar) with 100 PSIG (7 bar) inlet pressure, 100 PSIG (7 bar) with 60 PSIG (4.2 bar) inlet pressure.

Actuator - 60 (4.2 bar) to 100 PSIG (7 bar)

Pressure ranges above are for operation at ambient temperature. For use at higher temperatures consult Pressure/Temperature chart on page 3.

Temperature Ranges:

0° - 150° F (-17° - 66° C) Ambient

0° - 266° F (-17° - 130° C) Fluid

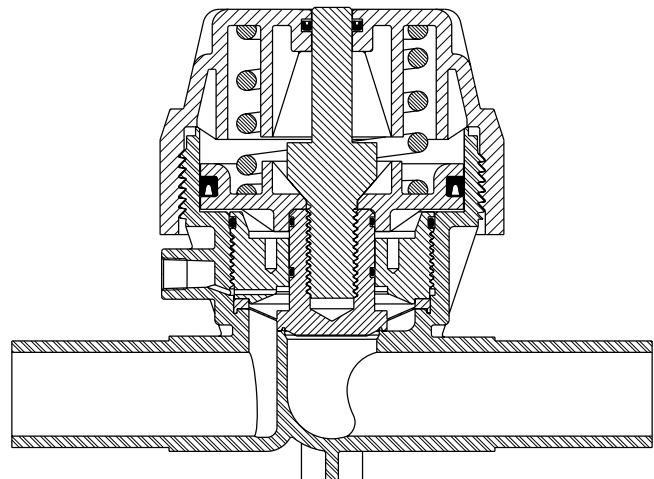

Normally Closed shown

PV-12 1" Pneumatic Valve

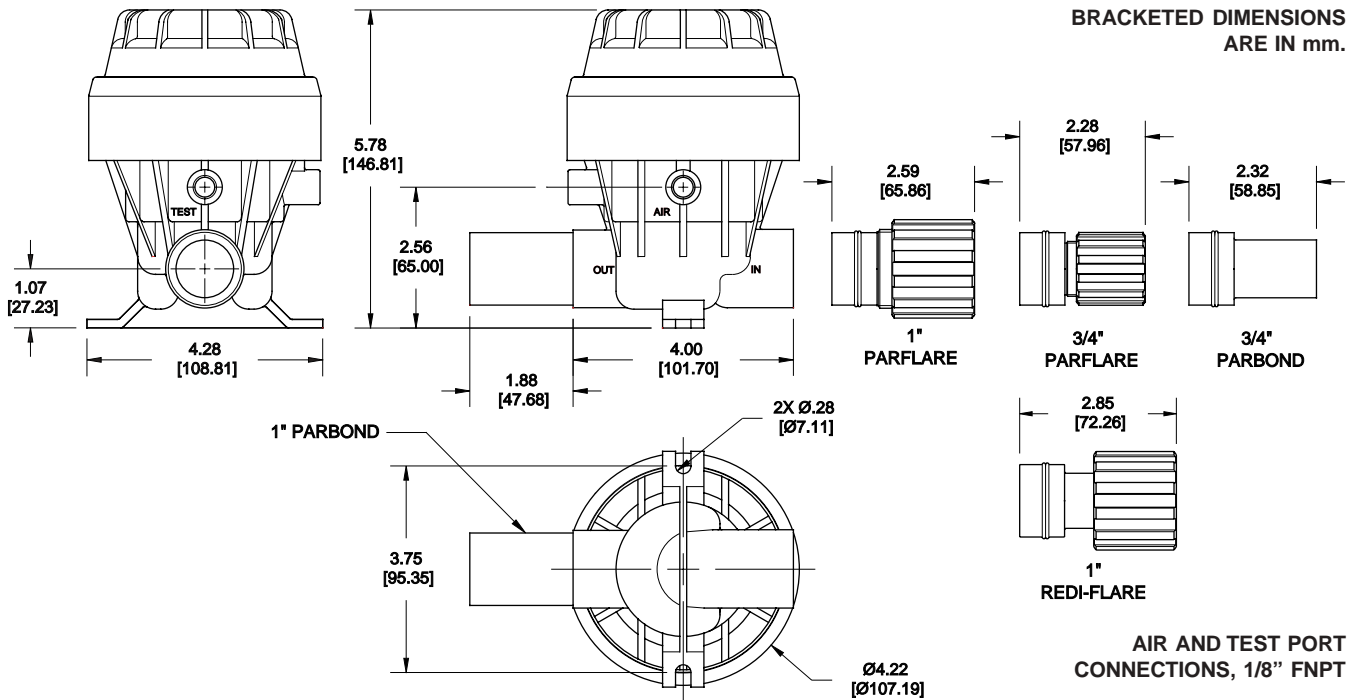

Model Number	Cv	Kv	Flow Configuration	Inlet Port	Outlet Port
PV-12-001	15.7	224.2	N C	1" Parbond	1" Parbond
PV-12-002	13.3	189.9	N C	1" Parflare	1" Parflare
PV-12-003	9.6	142.8	N C	3/4" Parbond	3/4" Parbond
PV-12-004	6.8	142.8	N C	3/4" Parflare	3/4" Parflare
PV-12-005	15.7	224.2	N O	1" Parbond	1" Parbond
PV-12-006	13.3	189.9	N O	1" Parflare	1" Parflare
PV-12-007	9.6	142.8	N O	3/4" Parbond	3/4" Parbond
PV-12-008	6.8	142.8	N O	3/4" Parflare	3/4" Parflare

Above Parflare model numbers are supplied with PVDF nuts. For PFA nuts add -T to model number. For high temperature nut assemblies, add -HT. Consult factory for delivery and pricing. Please consult factory for other available configurations, custom assemblies or flow position and leak sensor assemblies.

PRESSURE DROP VS. FLOW RATE

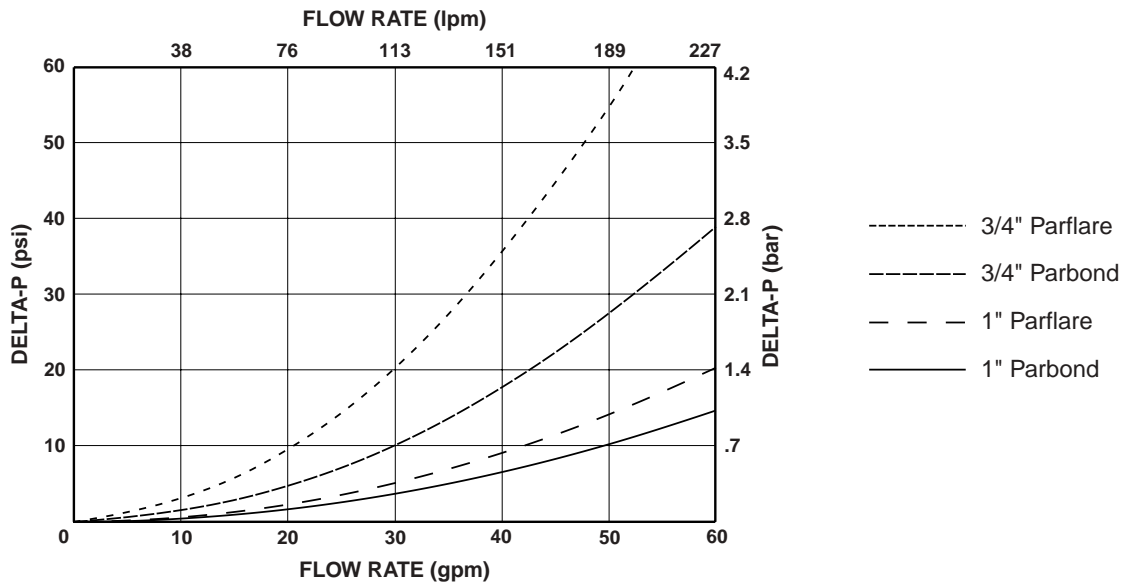

PV-13 CMP Valve

Product Overview

The PV-13 CMP Valve is designed for DI water, photoresist, and nitrogen services. The CMP Valve can be used in many high purity applications where dead legs in circuits must be eliminated. With a patent-pending self-cleaning spool design, the CMP Valve acts as a four way air operated valve shifting to deliver media when actuated and shifting by a spring return mechanism to a neutral center condition when de-actuated. In all positions two continuous loops operate independently preventing cross contamination.

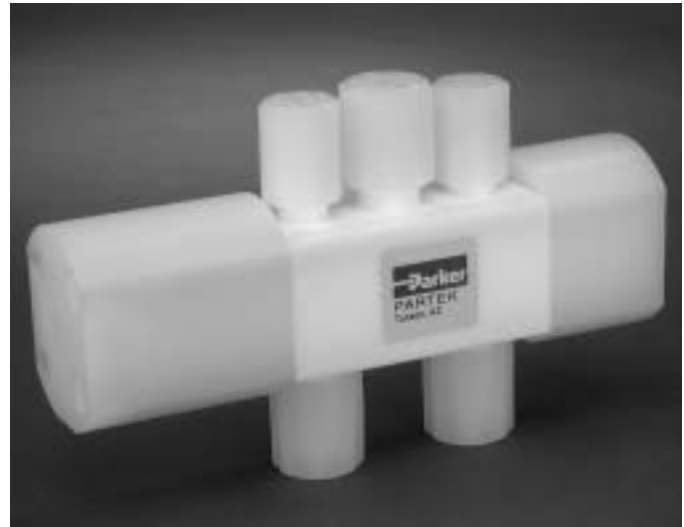

Features

Patent pending spool design.

Parofluor™ o-rings on the spool.

Eliminates dead legs.

Benefits

Prevents mixing and dilution of two dissimilar compounds.

Act as wipers to self clean and contribute to the long life of the valve.

Consolidation of as many as three 3-way valves in a typical wafer polishing, chemical delivery, or DI/ Nitrogen purge system.

Specifications

Materials of Construction:

Wetted Surfaces - PTFE, Parofluor™
External Surfaces - PVDF, SS.

Pressure Ranges:

0 to 40 PSIG (2.8 bar)

Pressure ranges above are for operation at ambient temperature. For use at higher temperatures consult Pressure/Temperature chart on page 3.

Temperature Ranges:

0° - 150° F (-17° - 66° C) Ambient

0° - 200° F (-17° - 93° C) Fluid

Port Sizes:

Control Port: 3/8" Parflare

Continuous Loop Ports: 1/4" Parflare

Actuation Ports: 1/4" FNPT

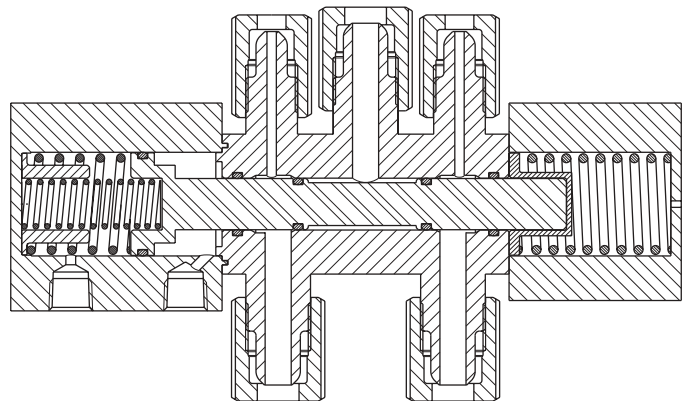

PV-13 CMP Valve

BRACKETED DIMENSIONS
ARE IN mm.

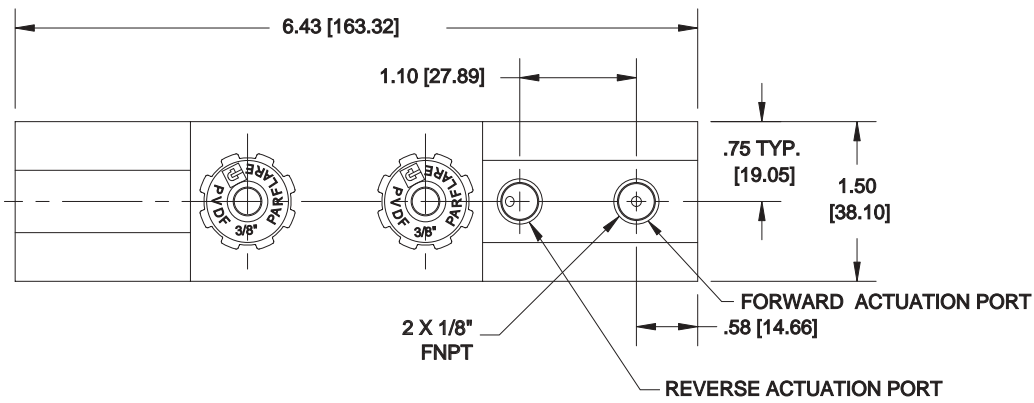
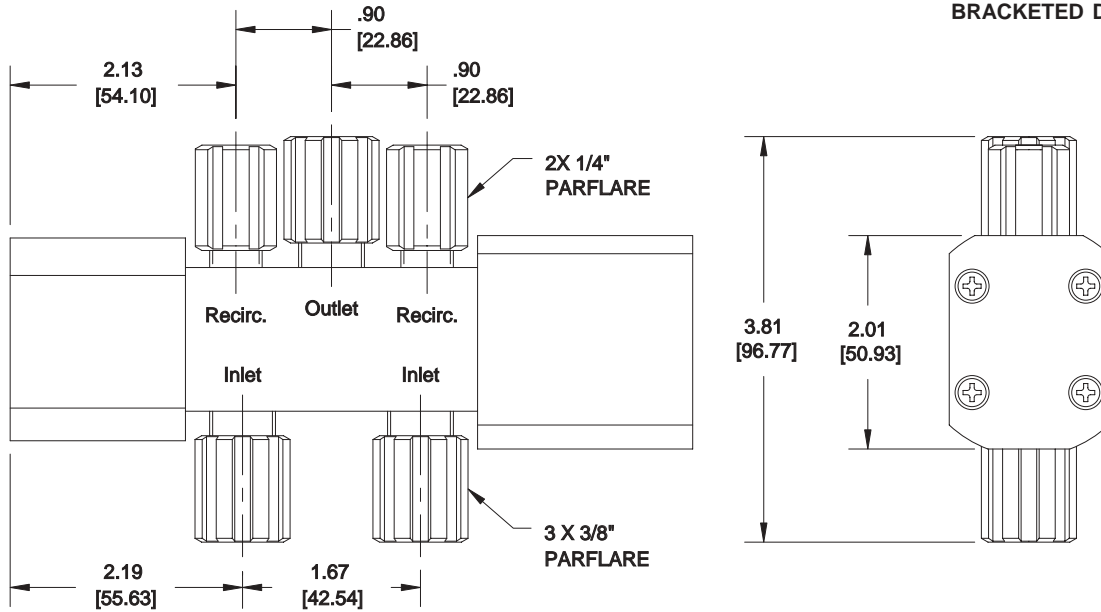

PRESSURE DROP VS. FLOW RATE

Model Number	Outlet Cv	Outlet Kv	Recirc. Cv	Recirc. Kv	Inlet Config.	Outlet Config.	Recirc. Config.
PV-13-001	.63	8.9	.14	1.9	3/8" Parflare	3/8" Parflare	1/4" Parflare

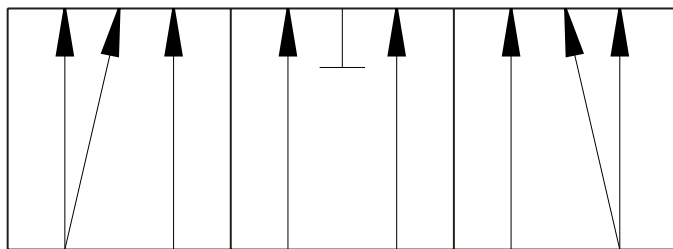

Forward Actuated Position

Unactuated Position

Reverse Actuated Position

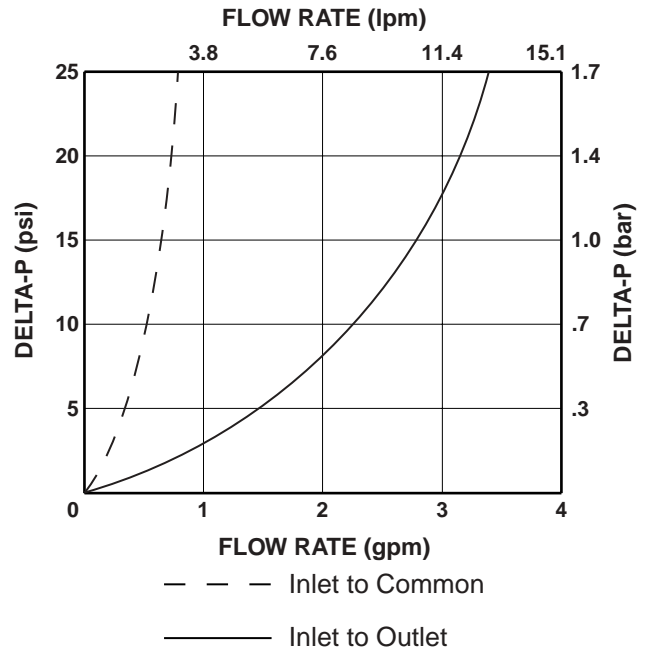

PV-14 3/8" Pneumatic Valve

Product Overview

The PV-14 Diaphragm Valve is designed for use in high purity semiconductor applications. It is also ideally suited for ultra-pure water and aggressive chemical or gas applications. The design utilizes a high purity PTFE body with precision machined areas. A machined modified PTFE diaphragm is also utilized for excellent flexibility and life. The custom nature of this product allows for various porting configurations and sizes to be produced in a compact package.



Features

Precision machined diaphragm manufactured from the latest technology modified PTFE. Provides over five times the flexural life as compared to conventional PTFE.

Tongue and groove seat and diaphragm for positive through flow shut off and diaphragm to body seal.

Modified flow configurations with numerous end connections including Parflare available.

Benefits

High cycle life.

Lower replacement costs.

Less downtime.

Provides system integrity.

Reduces connections, mounting space, and overall cost.

Specifications

Materials of Construction:

Wetted Surfaces - PTFE, Modified PTFE

Non Wetted Surfaces - PTFE, PVDF

Other Materials - Viton Seals, PVDF coated stainless steel spring.

Pressure Ranges:

Forward - 27" Hg vacuum (913 mbar) to 100 PSIG (7 bar)

Back - 27" Hg Vacuum (913 mbar) to 100 PSIG (7 bar)

Pressure ranges above are for operation at ambient temperatures. For use at higher temperatures consult Pressure/Temperature chart on page 3.

Temperature Ranges:

0° - 150° F (-17° - 66° C) Ambient

0° - 266° F (-17° - 130° C) Fluid

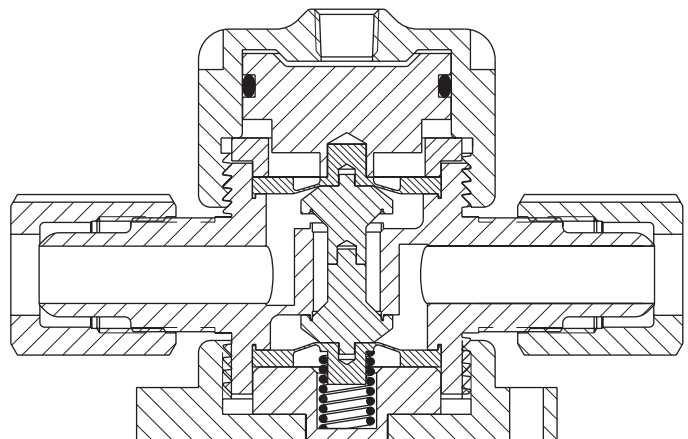

PV-14 3/8" Pneumatic Valve

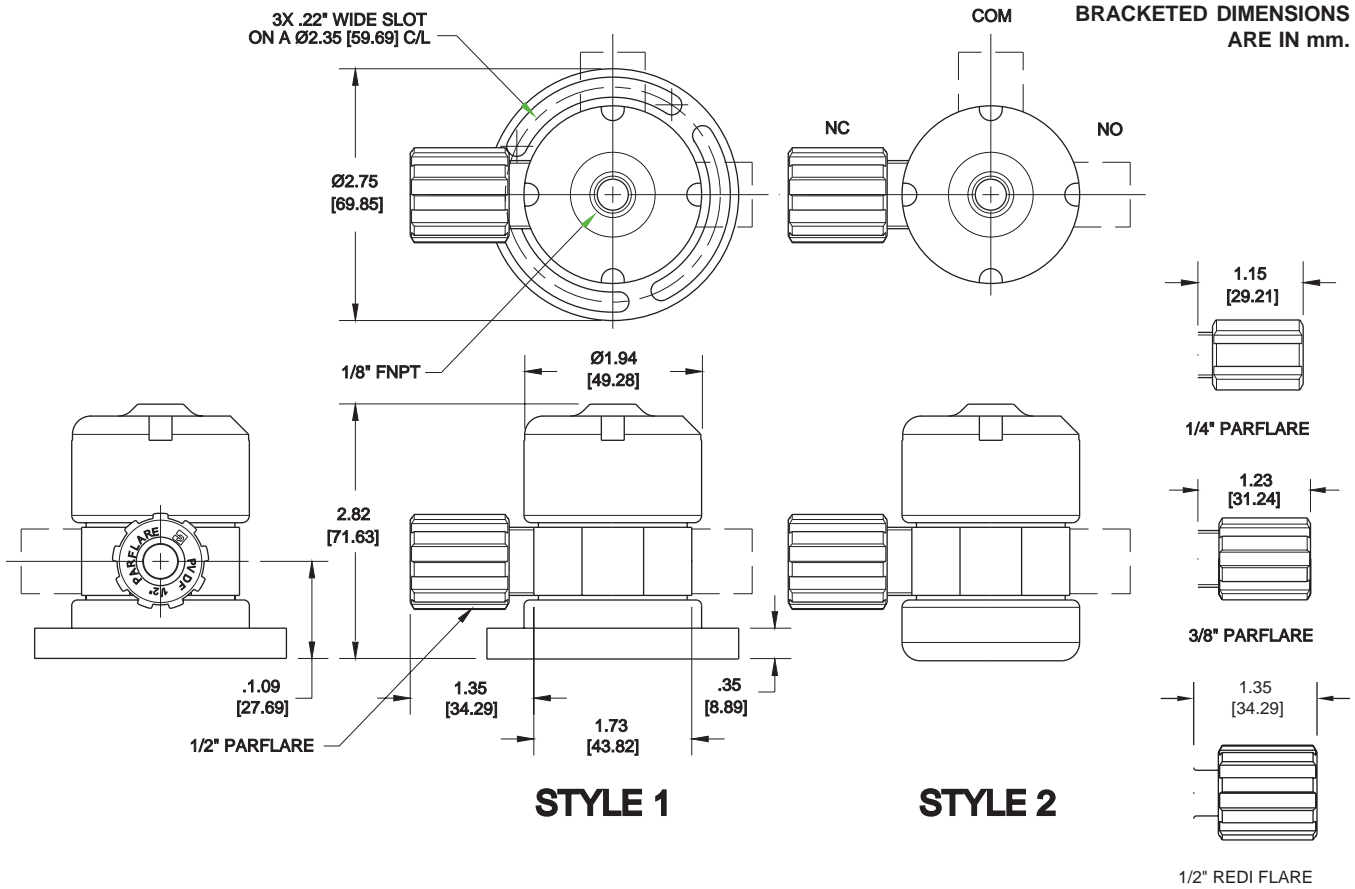

Model Number	Style	Cv	Kv	Flow Config.	Port Configuration
PV-14-001	2	.81	11.6	NC	1/2" Parflare
PV-14-007	2	.24	3.4	"	1/4" Parflare
PV-14-008	2	.35	4.9	"	3/8" Parflare
PV-14-010	1	.67	9.6	3 WAY	1/2" Redi-flare X 1/2" Parflare X 1/2" Parflare
PV-14-011	1	.67	9.6	"	1/2" Parflare Reversed COM/NC
PV-14-016	1	.67	9.6	"	1/2" Parflare Reversed NO/NC

PRESSURE DROP VS. FLOW RATE

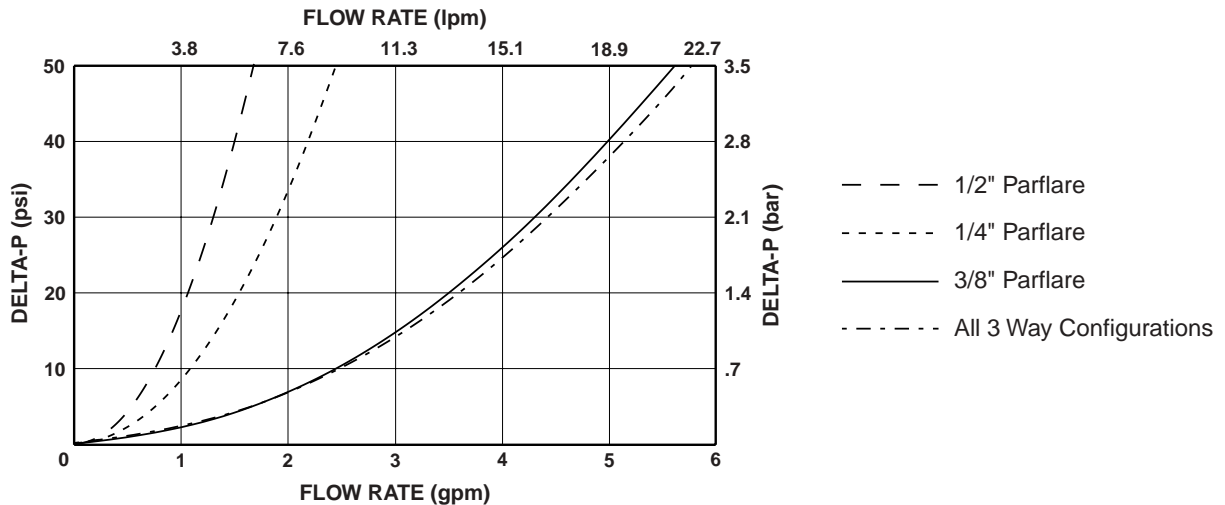

CV-1 Check Valve

Product Overview

The CV-1 Check Valve is designed for use in high purity semiconductor applications, and is also ideally suited for ultra-pure water and aggressive chemical or gas applications. The design utilizes machined PTFE components to provide superior chemical resistance and purity without requiring o-rings for sealing. The machined PTFE spring allows for low cracking pressure operation and minimal back pressure for resealing.



Features

Polished sealing surfaces.

Tongue and groove external seal.

Machined PTFE spring.

Numerous end configurations available including Parflare. Available with different configurations on either end.

Benefits

Long life and superior sealing characteristics.

Eliminates o-rings and compatibility problems.

Low cracking pressure.

Reduces connections, mounting space, and overall cost.

Specifications

Materials of Construction:

Wetted Surfaces - PTFE
External Surfaces - PFA, PVDF, ETFE

Cracking Pressure:

0.25 - 0.75 PSIG (.017 - .052 bar)

Back Check Sealing Pressure:

5.0 PSIG (.35 bar)

Pressure Range:

27" Hg vacuum (913 mbar) to 120 PSIG (8.3 bar)

Pressure ranges above are for operation at ambient temperature. For use at higher temperatures consult Pressure/Temperature chart on page 3.

Temperature Ranges:

0° - 212° F (-17° - 100° C) Ambient

0° - 266° F (-17° - 130° C) Fluid

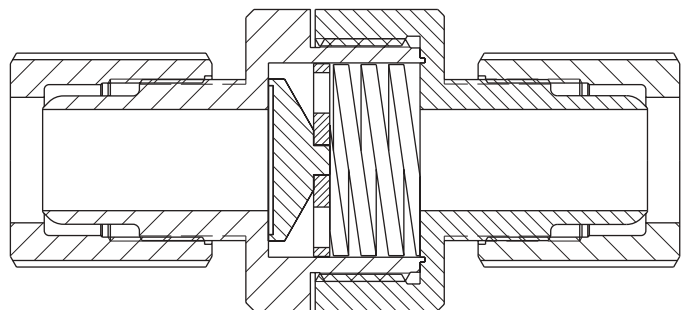

CV-1 Check Valve

Model Number	Cv	Kv	Style	Inlet Port	Outlet Port
CV-1-1122	0.61	8.78	1	1/8" FNPT	1/8" FNPT
CV-1-1144	1.51	21.74	1	1/4" FNPT	1/4" FNPT
CV-1-1166	2.43	35.00	2	3/8" FNPT	3/8" FNPT
CV-1-1188	4.22	60.77	3	1/2" FNPT	1/2" FNPT
CV-111616	14.00	201.6	5	1" FNPT	1" FNPT
CV-1-2222	0.02	0.29	1	1/8" Pargrip	1/8" Pargrip
CV-1-2244	0.34	4.90	1	1/4" Pargrip	1/4" Pargrip

Model Number	Cv	Kv	Style	Inlet Port	Outlet Port
CV-1-2266	.98	14.11	1	3/8" Pargrip	3/8" Pargrip
CV-1-2288	2.17	31.25	2	1/2" Pargrip	1/2" Pargrip
CV-1-6644	.26	3.74	1	1/4" Parflare	1/4" Parflare
CV-1-6666	1.11	15.84	1	3/8" Parflare	3/8" Parflare
CV-1-6688	2.03	29.23	2	1/2" Parflare	1/2" Parflare
CV-1-661212	4.13	59.47	3	3/4" Parflare	3/4" Parflare
CV-1-661616	11.85	170.6	4	1" Parflare	1" Parflare

Above Pargrip model numbers are supplied with PFA nuts, and Parflare models are supplied with PVDF nuts. For PFA nuts add -T to model number. Please consult factory for other available configurations or custom assemblies.

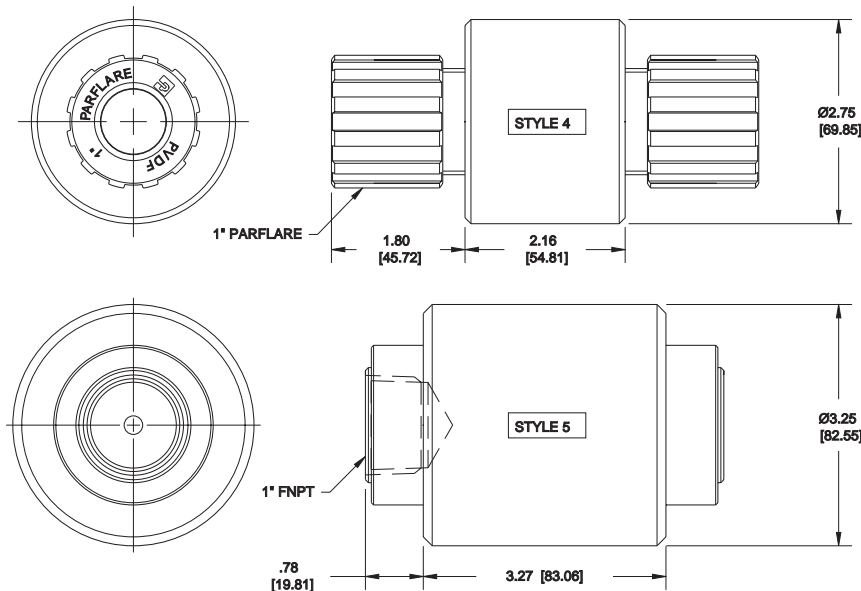
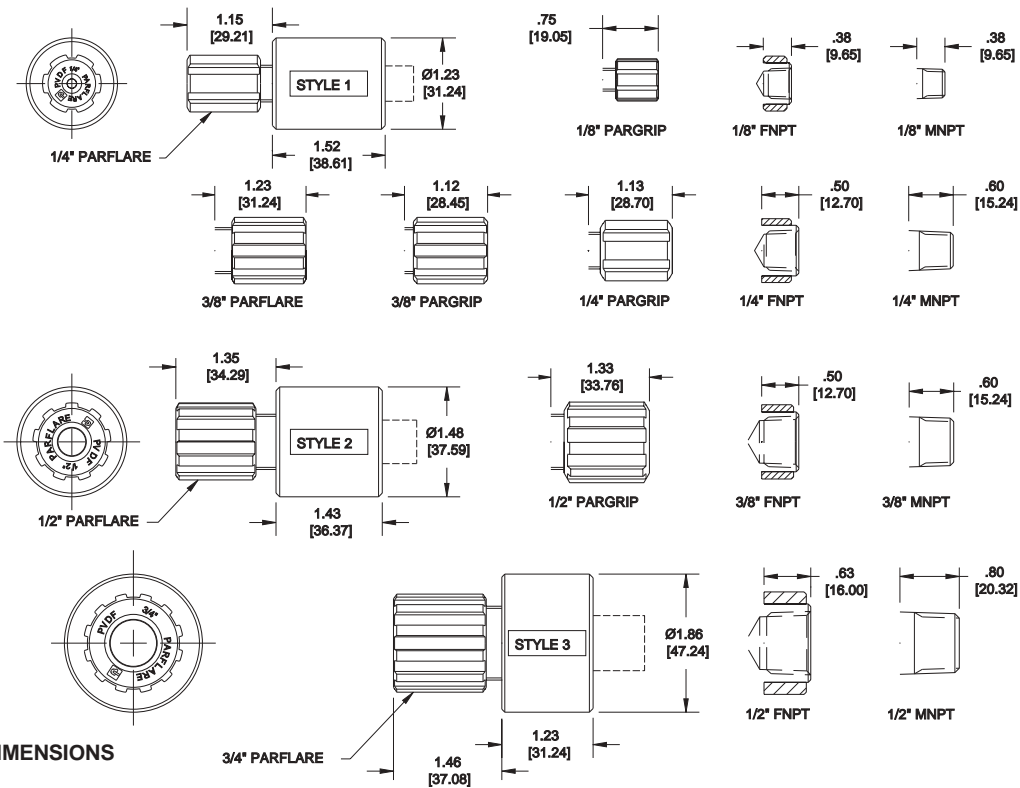

RV Relief Valve

Product Overview

The RV Relief Valve is designed for use in high purity semiconductor applications, and is also ideally suited for ultra-pure water and aggressive chemicals. The design utilizes a machined PTFE body with precision-machined PTFE seats and diaphragm poppet. When a factory preset or field set relief pressure is reached, the valve opens and permits flow. The valve resets when 25% of original setpoint is reached.

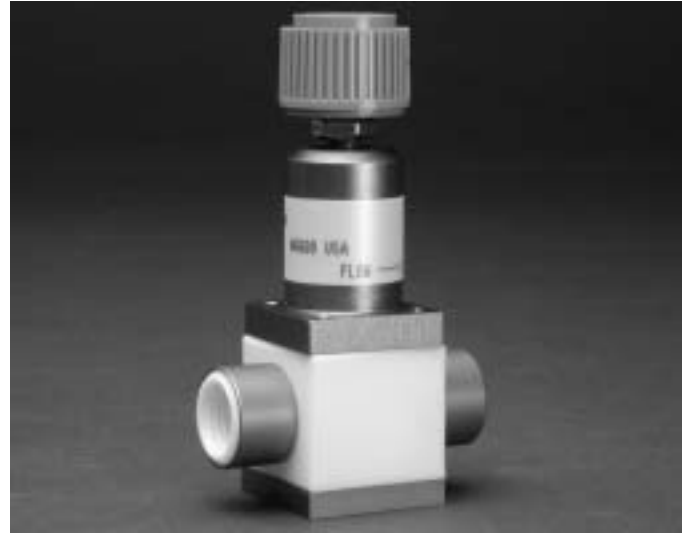

Features

One piece precision machined diaphragm poppet manufactured from the latest technology modified PTFE.

Provides over five times the flexural life as compared to conventional PTFE.

Tongue and groove seat and diaphragm poppet for positive through flow shut off and diaphragm to body seal.

Factory set or field adjustable relief pressure.

Benefits

High cycle life.

Lower replacement costs.

Less downtime.

Isolates media from adjusting screw.

Prevent over pressurization in critical applications.

Specifications

Materials of Construction:

Wetted Surfaces - PTFE, Modified PTFE

Non Wetted Surfaces - Anodized Aluminum, ABS, SS, Brass, PVDF, HDPE.

Pressure Ranges:

20 to 120 PSIG (1.4 to 8.3 bar)

Pressure ranges above are for operation at ambient temperature. For use at higher temperatures consult Pressure/Temperature chart on page 3.

Temperature Ranges:

0° F - 150° F (-17° - 66° C) Ambient

0° F - 266° F (-17° - 130° C) Fluid

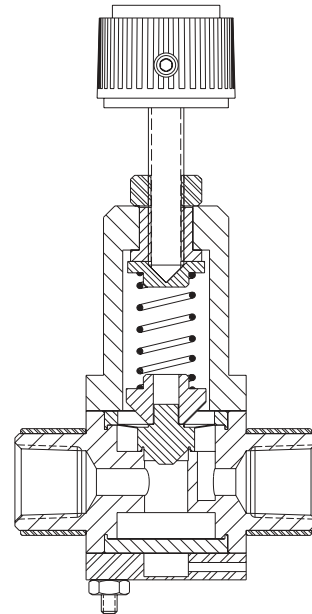

RV Relief Valve

BRACKETED DIMENSIONS
ARE IN mm.

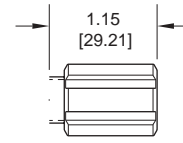
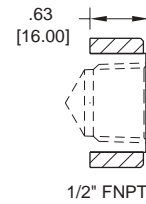
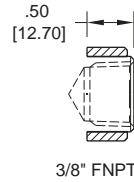
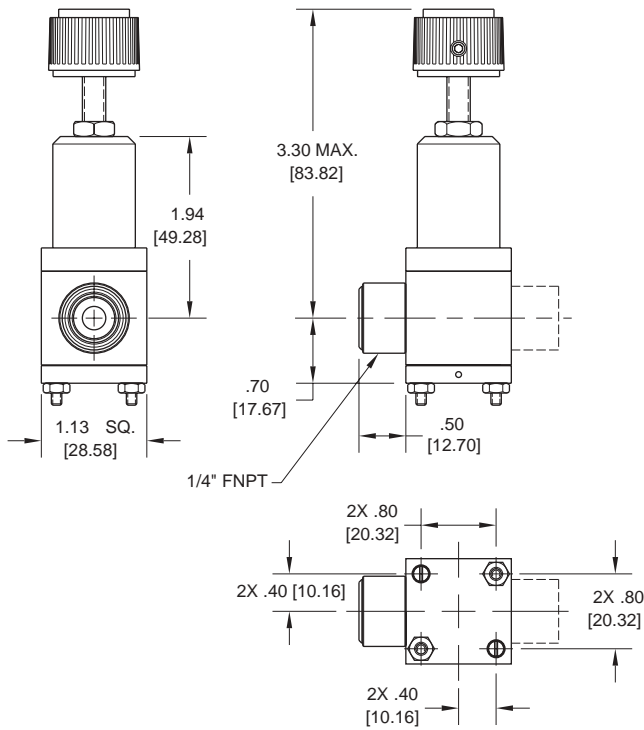

1/4" PARFLARE

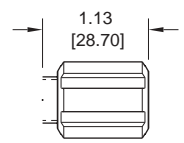

1/4" PARGRIP

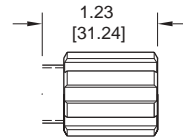

3/8" PARFLARE

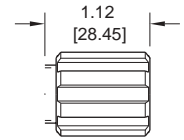

3/8" PARGRIP

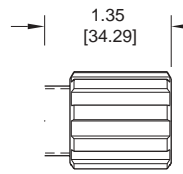

1/2" PARFLARE

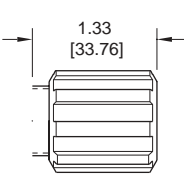

1/2" PARGRIP

Model Number	Cv	Kv	Flow Config.	Port Configuration
RV-144-0	.35	5.0	ON/OFF	1/4" FNPT
RV-234-0	.20	2.9	"	1/4" Pargrip
RV-246-0	.35	5.0	"	3/8" Pargrip
RV-248-0	.35	5.0	"	1/2" Pargrip
RV-624-0	.09	1.3	"	1/4" Parflare
RV-646-0	.35	5.0	"	3/8" Parflare
RV-648-0	.35	5.0	"	1/2" Parflare

Above Parflare model numbers are supplied with PVDF nuts. For PFA nuts add -T to model number. For high temperature nut assemblies, add -HT. Consult factory for delivery and pricing. Please consult factory for other available configurations or custom assemblies.

Offer of Sale

The items described in this document and other documents or descriptions provided by Parker Hannifin Corporation, its subsidiaries and its authorized distributors are hereby offered for sale at prices to be established by Parker Hannifin Corporation, its subsidiaries and its authorized distributors. This offer and its acceptance by any customer ("Buyer") shall be governed by all of the following Terms and Conditions. Buyer's order for any such items, when communicated to Parker Hannifin Corporation, its subsidiary or an authorized distributor ("Seller") verbally or in writing, shall constitute acceptance of this offer.

1. Terms and Conditions of Sale: All descriptions, quotations, proposals, offers, acknowledgments, acceptances and sales of Seller's products are subject to and shall be governed exclusively by the terms and conditions stated herein. Buyer's acceptance of any offer to sell is limited to these terms and conditions. Any terms or conditions in addition to, or inconsistent with those stated herein, proposed by Buyer in any acceptance of an offer by Seller, are hereby objected to. No such additional, different or inconsistent terms and conditions shall become part of the contract between Buyer and Seller unless expressly accepted in writing by Seller. Seller's acceptance of any offer to purchase by Buyer is expressly conditional upon Buyer's assent to all the terms and conditions stated herein, including any terms in addition to, or inconsistent with those contained in Buyer's offer. Acceptance of Seller's products shall in all events constitute such assent.

2. Payment: Payment shall be made by Buyer net 30 days from the date of delivery of the items purchased hereunder. Amounts not timely paid shall bear interest at the maximum rate permitted by law for each month or portion thereof that the Buyer is late in making payment. Any claims by Buyer for omissions or shortages in a shipment shall be waived unless Seller receives notice thereof within 30 days after Buyer's receipt of the shipment.

3. Delivery: Unless otherwise provided on the face hereof, delivery shall be made F.O.B. Seller's plant. Regardless of the method of delivery, however, risk of loss shall pass to Buyer upon Seller's delivery to a carrier. Any delivery dates shown are approximate only and Seller shall have no liability for any delays in delivery.

4. Warranty: Seller warrants that the items sold hereunder shall be free from defects in material or workmanship for a period of 18 months from date of shipment from Parker Hannifin Corporation. **THIS WARRANTY COMPRISES THE SOLE AND ENTIRE WARRANTY PERTAINING TO ITEMS PROVIDED HEREUNDER. SELLER MAKES NO OTHER WARRANTY, GUARANTEE, OR REPRESENTATION OF ANY KIND WHATSOEVER. ALL OTHER WARRANTIES, INCLUDING BUT NOT LIMITED TO, MERCHANTABILITY AND FITNESS FOR PURPOSE, WHETHER EXPRESS, IMPLIED, OR ARISING BY OPERATION OF LAW, TRADE USAGE, OR COURSE OF DEALING ARE HEREBY DISCLAIMED. NOTWITHSTANDING THE FOREGOING, THERE ARE NO WARRANTIES WHATSOEVER ON ITEMS BUILT OR ACQUIRED WHOLLY OR PARTIALLY, TO BUYER'S DESIGNS OR SPECIFICATIONS.**

5. Limitation Of Remedy: SELLER'S LIABILITY ARISING FROM OR IN ANY WAY CONNECTED WITH THE ITEMS SOLD OR THIS CONTRACT SHALL BE LIMITED EXCLUSIVELY TO REPAIR OR REPLACEMENT OF THE ITEMS SOLD OR REFUND OF THE PURCHASE PRICE PAID BY BUYER, AT SELLER'S SOLE OPTION. IN NO EVENT SHALL SELLER BE LIABLE FOR ANY INCIDENTAL, CONSEQUENTIAL OR SPECIAL DAMAGES OF ANY KIND OR NATURE WHATSOEVER, INCLUDING BUT NOT LIMITED TO LOST PROFITS ARISING FROM OR IN ANY WAY CONNECTED WITH THIS AGREEMENT OR ITEMS SOLD HEREUNDER, WHETHER ALLEGED TO ARISE FROM BREACH OF CONTRACT, EXPRESS OR IMPLIED WARRANTY, OR IN TORT, INCLUDING WITHOUT LIMITATION, NEGLIGENCE, FAILURE TO WARN OR STRICT LIABILITY.

6. Changes, Reschedules and Cancellations: Buyer may request to modify the designs or specifications for the items sold hereunder as well as the quantities and delivery dates thereof, or may request to cancel all or part of this order, however, no such requested modification or cancellation shall become part of the contract between Buyer and Seller unless accepted by Seller in a written amendment to this Agreement. Acceptance of any such requested modification or cancellation shall be at Seller's discretion, and shall be upon such terms and conditions as Seller may require.

7. Special Tooling: A tooling charge may be imposed for any special tooling, including without limitation, dies, fixtures, molds and patterns, acquired to manufacture items sold pursuant to this contract. Such special tooling shall be and remain Seller's property notwithstanding payment of any charges by Buyer. In no event will Buyer acquire any interest in apparatus belonging to Seller which is utilized in the notwithstanding any charges paid by Buyer. Unless otherwise agreed, Seller shall have the right to alter, discard or otherwise dispose of any special tooling or other property in its sole discretion at any time.

8. Buyer's Property: Any designs, tools, patterns, materials, drawings, confidential information or equipment furnished by Buyer or any other items which become Buyer's property, may be considered obsolete and may be destroyed by Seller after two (2) consecutive years have elapsed without Buyer placing an order for the items which are manufactured using such property, Seller shall not be responsible for any loss or damage to such property while it is in Seller's possession or control.

9. Taxes: Unless otherwise indicated on the face hereof, all prices and charges are exclusive of excise, sales, use, property, occupational or like taxes which may be imposed by any taxing authority upon the manufacture, sale or delivery of the items sold hereunder. If any such taxes must be paid by Seller or if Seller is liable for the collection of such tax, the amount thereof shall be in addition to the amounts for the items sold. Buyer agrees to pay all such taxes or to reimburse Seller therefore upon receipt of its invoice. If Buyer claims exemption from any sales, use or other tax imposed by any taxing authority, Buyer shall save Seller harmless from and against any such tax, together with any interest or penalties thereon which may be assessed if the items are held to be taxable.

10. Indemnity For Infringement of Intellectual Property Rights: Seller shall have no liability for infringement of any patents, trademarks, copyrights, trade dress, trade secrets or similar rights except as provided in this Part 10. Seller will defend and indemnify Buyer against allegations of infringement of U.S. Patents, U.S. Trademarks, copyrights, trade dress and trade secrets (hereinafter 'Intellectual Property Rights'). Seller will defend at its expense and will pay the cost of any settlement or damages awarded in an action brought against Buyer based on an allegation that an item sold pursuant to this contract infringes the Intellectual Property Rights of a third party. Seller's obligation to defend and indemnify Buyer is contingent on Buyer notifying Seller within ten (10) days after Buyer becomes aware of such allegations of infringement, and Seller having sole control over the defense of any allegations or actions including all negotiations for settlement or compromise. If an item sold hereunder is subject to a claim that it infringes the Intellectual Property Rights of a third party, Seller may, at its sole expense and option, procure for Buyer the right to continue using said item, replace or modify said item so as to make it noninfringing, or offer to accept return of said item and return the purchase price less a reasonable allowance for depreciation. Notwithstanding the foregoing, Seller shall have no liability for claims of infringement based on information provided by Buyer, or directed to items delivered hereunder for which the designs are specified in whole or part by Buyer, or infringements resulting from the modification, combination or use in a system of any item sold hereunder. The foregoing provisions of this Part 10 shall constitute Seller's sole and exclusive liability and Buyer's sole and exclusive remedy for infringement of Intellectual Property Rights.

If a claim is based on information provided by Buyer or if the design for an item delivered hereunder is specified in whole or in part by Buyer, Buyer shall defend and indemnify Seller for all costs, expenses or judgments resulting from any claim that such item infringes any patent, trademark, copyright, trade dress, trade secret or any similar right.

11. Force Majeure: Seller does not assume the risk of and shall not be liable for delay or failure to perform any of Seller's obligations by reason of circumstances beyond the reasonable control of Seller (hereinafter 'Events of Force Majeure'). Events of Force Majeure shall include without limitation, accidents, acts of God, strikes or labor disputes, acts, laws, rules or regulations of any government or government agency, fires, floods, delays or failures in delivery of carriers or suppliers, shortages of materials and any other cause beyond Seller's control.

12. Entire Agreement/Governing Law: The terms and conditions set forth herein, together with any amendments, modifications and any different terms or conditions expressly accepted by Seller in writing, shall constitute the entire Agreement concerning the items sold, and there are no oral or other representations or agreements which pertain thereto. This Agreement shall be governed in all respects by the law of the State of Ohio. No actions arising out of the sale of the items sold hereunder or this Agreement may be brought by either party more than two (2) years after the cause of action accrues.

9/91-P



Parker Hannifin Corporation
6035 Parkland Blvd.
Cleveland, Ohio 44124-4141
Telephone: (216) 896-3000
Fax: (216) 896-4000
www.parker.com

Parker Hannifin Corporation

About Parker Hannifin Corporation

Parker Hannifin is a leading global motion-control company dedicated to delivering premier customer service. A Fortune 500 corporation listed on the New York Stock Exchange (PH), our components and systems comprise over 1,400 product lines that control motion in some 1,000 industrial and aerospace markets. Parker is the only manufacturer to offer its customers a choice of hydraulic, pneumatic, and electromechanical motion-control solutions. Our Company has the largest distribution network in its field, with over 7,500 distributors serving nearly 400,000 customers worldwide.

Parker's Charter

To be a leading worldwide manufacturer of components and systems for the builders and users of durable goods. More specifically, we will design, market and manufacture products controlling motion, flow and pressure. We will achieve profitable growth through premier customer service.

Product Information

North American customers seeking product information, the location of a nearby distributor, or repair services will receive prompt attention by calling the Parker Product Information Center at our toll-free number: 1-800-C-PARKER (1-800-272-7537). In Europe, call 00800-C-PARKER-H (00800-2727-5374).

The Aerospace Group is a leader in the development, design, manufacture and servicing of control systems and components for aerospace and related high-technology markets, while achieving growth through premier customer service.

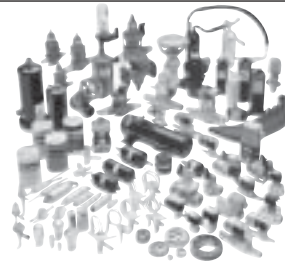

The Climate & Industrial Controls Group designs, manufactures and markets system-control and fluid-handling components and systems to refrigeration, air-conditioning and industrial customers worldwide.

The Fluid Connectors Group designs, manufactures and markets rigid and flexible connectors, and associated products used in pneumatic and fluid systems.



The Seal Group designs, manufactures and distributes industrial and commercial sealing devices and related products by providing superior quality and total customer satisfaction.

The Hydraulics Group designs, produces and markets a full spectrum of hydraulic components and systems to builders and users of industrial and mobile machinery and equipment.



The Filtration Group designs, manufactures and markets quality filtration and clarification products, providing customers with the best value, quality, technical support, and global availability.

The Automation Group is a leading supplier of pneumatic and electromechanical components and systems to automation customers worldwide.



The Instrumentation Group is a global leader in the design, manufacture and distribution of high-quality critical flow components for worldwide process instrumentation, ultra-high-purity, medical and analytical applications.

anything  Possible.™

Parker Hannifin Corporation
Partek/Atlantic
7075 East Southpoint Road
Tucson, AZ 85706 USA
Tel: (520) 574-2600
Fax: (520) 574-2700
Web site: <http://www.parker.com/partek>

Catalog 4182
04/03