

PRESSURE, DIFFERENTIAL PRESSURE, AND TEMPERATURE SWITCHES



FEATURES

- Stainless Steel Construction
- Hermetically Sealed Switch
- Convenient Field Adjustment
- 72" Leadwires with Strain Relief
- UL, cUL and ATEX Approved
- Adjustable Ranges:
 - Pressure: 1 to 6000 psi
(0,07 to 413,7 bar)
 - Differential Pressure:
0.7" wcd to 150 psid
(1,7 mbar to 10,3 bar)
 - Temperature: -130 to 650°F
(-90 to 340°C)





12 Series

12 Series

OVERVIEW

Spectra 12™ switches are ideal for operation in harsh explosive environments where space is at a premium. A snap-action Belleville spring assembly is used to provide vibration resistance and prolonged switch life. A hermetically sealed switch and stainless steel enclosure provide ruggedness and protection from the environment. The Spectra 12 is approved for use in hazardous locations worldwide, from offshore oil rigs to process and energy applications, to protection of capital equipment.

FEATURES

- Compact stainless steel construction
- Convenient field setting and adjustment
- UL, cUL and ATEX approved for Div. 1 or Zone 1 hazardous locations
- SPDT or DPDT hermetically sealed switches
- Snap-acting Belleville spring for long life, vibration resistance and stability
- Mounting bracket available for retrofit applications
- 3 year warranty
- 72" leadwires with strain relief



Optional Cover Locking Ring prevents incidental tampering.

Option M423 ATEX junction box

Option M513 UL junction box

Differential Pressure Model with mounting bracket

APPLICATIONS

Triple approval (UL, cUL and ATEX) means the Spectra 12 meets the demanding requirements of hazardous locations. It can be used in a wide variety of applications where space is at a premium. Ambient temperatures can be as low as -58°F (-50°C) or as high as 203°F (95°C). All metal wetted parts comply with NACE MR-0175. The stainless steel design and enclosure type 4X rating assure long-term performance in the toughest applications.

Offshore Platforms



Chemical Plants & Refineries



Instrument Panels



Rotating Equipment

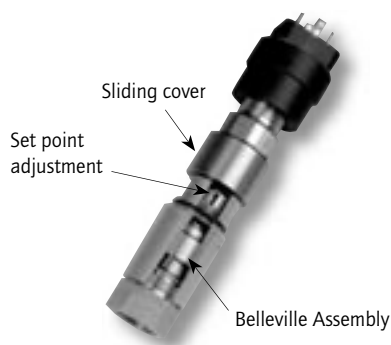
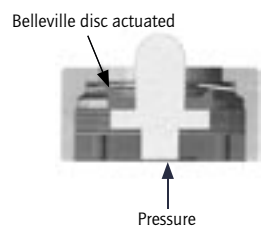
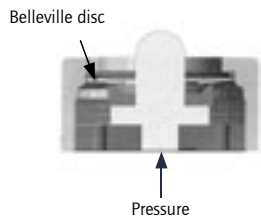

TECHNOLOGY

At the heart of the Spectra 12 is a Belleville spring assembly. The spring is a small conical washer that transfers motion to a hermetically sealed 1 or 5 amp microswitch. Its 'snap-action' provides fast, positive contact transfer. The Belleville spring 'snaps over' when pressure is applied and 'snaps back' upon pressure release.

Advantages:

- **Set point stability:** The switch performs under challenging environmental conditions such as vibration and temperature changes. In addition, minimal movement of components reduces sensor fatigue thereby increasing life and accuracy.
- **High over-pressures:** The Belleville spring mechanism limits "over-travel", extending pressure limits.
- **Resistance to vibration:** Preloading of the electrical switch helps reduce 'contact chatter.'
- **Maximum life:** The Belleville spring enhances cycle life with a short 'stroke' movement to minimize fatigue.
- **Small size:** Belleville springs are simple in appearance, but can deliver a heavy load with a relatively small deflection, contributing to an overall compact product envelope.
- **Deadbands:** The Belleville is a 'negative-rate' snap acting device, so on-off deadband values are wider at the low end of the range. To minimize deadbands, select a model with a set point at the higher end of the range whenever possible.



SPECIFICATIONS

STORAGE TEMPERATURE	-58° to 203°F (-50 to 95°C)
OPERATING AMBIENT TEMPERATURE	-58 to 203°F (-50 to 95°C). Set point shifts less than 1% of range for a 50°F (28°C) ambient temperature change. Slight ambient effects for 25-50' extra capillary length on temperature switch models, consult factory.
MEDIA TEMPERATURE	Pressure models: Sensor types 2, 7, 9: -50 to 400°F (-45 to 204°C) Sensor types 3, 4, 8: -20 to 200°F (-28 to 93°C) Sensor types 5, 6: 0 to 320°F (-18 to 160°C) Sensor type P: 0 to 200°F (-18 to 93°C) 20 to 250°F (-7 to 121 °C) for optional Viton sensor Differential pressure models: Sensor type K: 0 to 180°F (-18 to 82°C) 20 to 250°F (-7 to 121 °C) for optional Viton sensor Temperature models: See model chart.
SET POINT REPEATABILITY	Temperature models: ±1% of adjustable range Pressure models: Sensor types 2, P: ±1.5% of adjustable range Sensor types 3-9: ±1% of adjustable range Differential pressure models: K1 to K3 ±1%, K4 to K6 ±1.5% of adjustable range
SHOCK	Differential pressure and temperature models: set point repeats after 15 G's, 10 millisecond duration Pressure models: set point repeats after 75 G's, 10 milliseconds
VIBRATION	Differential pressure and temperature models: Set point repeats after 2.5 G's, 10-2000 Hz. Pressure models: Set point repeats after 15 G's, 10-2000 Hz
ENCLOSURE	300 series stainless steel
ENCLOSURE CLASSIFICATION	Certified to Enclosure Type 4X Class I, Division 1 product meets enclosure Type 7; Class II, Division I product meets enclosure type 9. Certified to IP66 requirements
SWITCH OUTPUT	Code S: One SPDT, hermetically sealed. Code D: Two SPDT for DPDT action, hermetically sealed
ELECTRICAL RATINGS	Code H: 5 A at 250 VAC, 5 A resistive and 3 A inductive at 28 VDC. Silver contacts Code L: 1 A at 125 VAC, 1 A resistive and 0.5 A inductive at 28 VDC Bifurcated gold contacts
ELECTRICAL CONNECTION	Code N: 1/2" NPT (male) with 72" leadwires Code M: M20 metric threads, 72" leads Option M515, 4 terminal DIN connector (DIN 43650 Form A) available SPDT only

WEIGHT	Temperature models: approximately 1 lb 14 oz. (0,85 kg) Pressure models: approximately 12 ounces (0,34 kg) Differential models: approximately 3 lb (1,4 kg)
TEMPERATURE ASSEMBLY	Non-toxic oil fill; 6 feet 304 stainless steel. Optional lengths available
TEMPERATURE DEADBAND	Typically 2% of range under laboratory conditions (70°F ambient circulating bath at a rate of 1/2°F per minute change)
PRESSURE CONNECTION	1/2" NPT (female) or 1/4" NPT (female). Option M511: 1/4" NPT (male) Differential pressure: 1/8" NPT (female) Piston models: 1/4" NPT (female)
MOUNTING	Pressure: May be pipe mounted or bracket mounted using kit 62169-13 Differential Pressure: Should be mounted using 2 mounting holes on sensor bracket Temperature: Mounting kit 62169-13 should be specified for new installations

APPROVALS



UNITED STATES AND CANADA

Class I, Division 1 & 2, Groups A, B, C & D

Class II, Division 1 & 2, Groups E, F & G

Class III

Class I, Zone 1, Groups IIC

Enclosure Type 4X

UL Listed, **cUL** Certified

Pressure: UL 508, 698; CSA C22.2 No. 14-M91,

25-1966, 30-1986, CEC Part 1 -- File #E40857

Temperature: UL 873, 1203; CSA C22.2 No. 24-M91, 25-1966, 30-

1986, CEC Part I -- File #E43374



CENELEC/TÜV Süddeutschland Bau und Betrieb GmbH (N.B. #0036)

TÜV certified to PED (97/23/EC)

Category IV, Module H1

Certificate #USA 02/04/38/001 thru USA 02/07/38/033

UEC Compliant to LVD (73/23/EC & 93/68/EEC)

Products rated lower than 50 VAC and 75 VDC are outside of the scope of the LVD

The Low Voltage Directive does not apply to products for use in hazardous locations



EUROPE

CENELEC/DEMKO A/S (N.B. #0539)

Demko A/S certified to **ATEX** Directive (94/9/EC)

II 2 G EEx d IIC T6, Tamb.= -50°C to +80°C (-58°F to +176°F), IP 66

II 2 D T+85°C, Tamb.= -50°C to +80°C (-58°F to +176°F), IP 66

EN 50 014, EN 50 018, EN 50 281, EN 60529

Certificate #DEMKO 03 ATEX 0252466X

II 1 G EEx ia IIC T6, Tamb.= -50°C to +60°C

EN 50014, EN 50020, EN 50284, EN 60079

Certificate #DEMKO 03 ATEX 0335063 (Must select option code

M405)



RUSSIA

Gosgortekhnadzor Permit (Must select option code M406)

1Exd IIC T6 X, Tamb.= -56°C to +71°C

Certificate #RRS 04-8895

OExia IIC T6, Tamb.= -50°C to +60°C

Certificate #RRS 04-8897





12 Series

12 Series

MODEL CHART

Model	Adjustable Range Lower end of range on fall; High end of range on rise	Deadband	Over Range Pressure*	Proof Pressure**
-------	--	----------	-------------------------	------------------

Sensor Type 2, 316 stainless steel 1/2" NPT (female) pressure connection and welded diaphragm, 23/32" orifice for clean out purposes. High proof pressure. Not recommended for high cycling applications.

	psi	bar	psi	bar	psi	bar	psi	bar
A	10 to 25	0,7 to 1,7	2 to 7	0,1 to 0,5	1000	68,9	2500	172,4
B	15 to 45	1,0 to 3,1	3 to 10	0,2 to 0,7	1000	68,9	2500	172,4
C	25 to 85	1,7 to 5,9	5 to 20	0,3 to 1,4	1000	68,9	2500	172,4
D	50 to 130	3,4 to 9,0	7 to 25	0,5 to 1,7	1500	103,4	2500	172,4
E	100 to 210	6,9 to 14,5	8 to 30	0,6 to 2,1	1500	103,4	2500	172,4
F	160 to 400	11,0 to 27,6	10 to 50	0,7 to 3,4	1500	103,4	2500	172,4
G	275 to 850	19,0 to 58,6	40 to 125	2,8 to 8,6	1500	103,4	2500	172,4

Sensor Type 3, 316L stainless steel 1/2" NPT (female) pressure connection, Teflon® coated Polyimide (Kapton®) diaphragm, Buna N O-ring, 1/2" orifice for clean out purposes.

Sensor Type 4, 316L stainless steel 1/4" NPT (female) pressure connection, Teflon® coated Polyimide (Kapton®) diaphragm, Buna N O-ring, 1/8" orifice.

	psi	bar	psi	bar	psi	bar	psi	bar
A	8 to 30	0,6 to 2,1	2 to 6	0,1 to 0,4	600	41,4	1000	68,9
B	15 to 55	1,0 to 3,8	3 to 8	0,2 to 0,6	600	41,4	1000	68,9
C	30 to 170	2,1 to 11,7	5 to 15	0,3 to 1,0	600	41,4	1000	68,9
D	100 to 370	6,9 to 25,5	15 to 50	1,0 to 3,4	600	41,4	1000	68,9
E	200 to 700	13,8 to 48,3	40 to 90	2,8 to 6,2	1500	103,4	3000	206,8
F	400 to 1500	27,6 to 103,4	100 to 250	6,9 to 17,2	3000	206,8	4500	310,3
G	1000 to 3200	68,9 to 220,6	100 to 500	6,9 to 34,5	6000	413,7	10000	689,5
H	2000 to 6000	137,9 to 413,7	400 to 800	27,6 to 55,2	8000	551,6	10000	689,5

***Over Range Pressure:** The maximum pressure that may be applied continuously without causing damage and maintaining set point repeatability.

****Proof Pressure:** The maximum pressure to which a pressure sensor may be occasionally subjected, which causes no permanent damage. The unit may require calibration (e.g., start-up, testing).

Model	Adjustable Range Lower end of range on fall; High end of range on rise	Deadband	Over Range Pressure*	Proof Pressure**
-------	--	----------	-------------------------	------------------

Sensor Type 5, 316L stainless steel 1/2" NPT (female) 1/2" pressure connection and diaphragm, Viton® O-ring, 1/2" orifice for clean out purposes. Other materials available, consult UE.

Sensor Type 6, 316L stainless steel 1/4" NPT (female) pressure connection and diaphragm, Viton® O-ring, 1/8" orifice. Other materials available, consult UE.

	psi	bar	psi	bar	psi	bar	psi	bar
A	9 to 35	0,6 to 2,4	2 to 7	0,1 to 0,5	600	41,4	1000	68,9
B	25 to 65	1,7 to 4,5	3 to 10	0,2 to 0,7	600	41,4	1000	68,9
C	50 to 150	3,4 to 10,3	5 to 15	0,3 to 1,0	600	41,4	1000	68,9
D	100 to 350	6,9 to 24,1	15 to 50	1,0 to 3,4	600	41,4	1000	68,9
E	250 to 700	17,2 to 48,3	40 to 95	2,8 to 6,6	1500	103,4	3000	206,8
F	400 to 1500	27,6 to 103,4	100 to 300	6,9 to 20,7	3000	206,8	4500	310,3
G	1000 to 3200	68,9 to 220,6	100 to 500	6,9 to 34,5	6000	413,7	10000	689,5
H	2000 to 6000	137,9 to 413,7	400 to 1000	27,6 to 68,9	8000	551,6	10000	689,5

Sensor Type 7, 1/2" 316L stainless steel NPT (female) pressure connection and welded diaphragm. Large 23/32" orifice for clean out purposes.

	psi	bar	psi	bar	psi	bar	psi	bar
A	3 to 15	0,2 to 1,0	1 to 4	0,1 to 0,3	300	20,7	500	34,5
B	10 to 35	0,7 to 2,4	1 to 6	0,1 to 0,4	300	20,7	500	34,5
C	25 to 85	1,7 to 5,9	3 to 11	0,2 to 0,8	300	20,7	500	34,5
D	65 to 125	4,5 to 8,6	6 to 18	0,4 to 1,2	300	20,7	500	34,5

Sensor Type 8, 316L stainless steel 1/4" NPT (female) pressure connection, Teflon® coated Polyimide (Kapton®) diaphragm, Buna N O-ring, 1/8" orifice. Non-Belleville actuation.

	psi	bar	psi	bar (unless noted)	psi	bar	psi	bar
A	2 to 25	0,14 to 1,7	0.5 to 4	34,5 mbar to 0,3 bar	600	41,4	1000	68,9
B	15 to 75	1,0 to 5,2	1 to 7	0,1 to 0,5	600	41,4	1000	68,9
C	25 to 150	1,7 to 10,3	1 to 12	0,1 to 0,8	600	41,4	1000	68,9
D	50 to 450	3,4 to 31,0	3 to 28	0,2 to 1,9	2000	137,9	3000	206,8
E	100 to 900	6,9 to 62,1	10 to 60	0,7 to 4,1	2000	137,9	3000	206,8
F	500 to 2500	34,5 to 172,4	20 to 140	1,4 to 9,7	6000	413,7	7500	517,1
G	700 to 4000	48,3 to 275,8	40 to 250	2,8 to 17,2	6000	413,7	7500	517,1

Application Note: The use of metallic diaphragms where higher pressure shock or heavy cycling is expected should be avoided. Sensor Type 7 to 9 should not be used where system or startup vacuum pressure might exceed 26" Hg Vac.

***Over Range Pressure:** The maximum pressure that may be applied continuously without causing damage and maintaining set point repeatability.

****Proof Pressure:** The maximum pressure to which a pressure sensor may be occasionally subjected, which causes no permanent damage. The unit may require calibration (e.g., start-up, testing).

Kapton® and **Teflon®** are registered trademarks of E. I. DuPont.

Viton® is a registered trademark of Dupont dow elastomers.

MODEL CHART

Model	Adjustable Range Lower end of range on fall; High end of range on rise		Deadband		Over Range Pressure*		Proof Pressure**	
	psi	bar	psi	mbar (unless noted)	psi	bar	psi	bar
Sensor Type 9 , 316L stainless steel 1/2" NPT (female) pressure connection and welded diaphragm. Large 23/32" orifice for clean-out purposes. Non-Belleville actuation.								
A	1 to 15	0,1 to 1,0	0.5 to 2	34,5 to 137,9	300	20,7	500	34,5
B	3 to 50	0,2 to 3,4	0.5 to 4	34,5 to 275,8	300	20,7	500	34,5
C	5 to 100	0,3 to 6,9	1.0 to 8	0,1 to 06 bar	300	20,7	500	34,5
Sensor Type P , 303 stainless steel piston and 1/4" NPT (female) pressure connection, Buna N O-Ring. Non-Belleville actuation.								
	psi	bar	psi	bar	psi	bar	psi	bar
1	300 to 1200	20,7 to 82,7	30 to 200	2,1 to 13,8	6000	413,7	10000	689,5
2	600 to 2600	41,4 to 179,3	50 to 350	3,4 to 24,1	6000	413,7	10000	689,5
3	1200 to 5500	82,7 to 379,2	100 to 800	6,9 to 55,2	6000	413,7	10000	689,5

***Over Range Pressure:** The maximum pressure that may be applied continuously without causing damage and maintaining set point repeatability.

****Proof Pressure:** The maximum pressure to which a pressure sensor may be occasionally subjected, which causes no permanent damage. The unit may require calibration (e.g., start-up, testing).

Application Note: The use of metallic diaphragms where higher pressure shock or heavy cycling is expected should be avoided. Sensor Type 7 to 9 should not be used where system or startup vacuum pressure might exceed 26" Hg Vac.

Differential Pressure Model Chart

Model	Adjustable Range Lower end of range on fall; High end of range on rise	Deadband	Working Pressure Range***	Proof Pressure**
-------	--	----------	---------------------------	------------------

Sensor Type K, epoxy coated aluminum pressure housing with Kapton® diaphragm, Buna N sealing diaphragms and 1/8" NPT (female) pressure connections. Non-Belleville actuation. 303/304 stainless steel mounting bracket attached.

SPDT Switch (single pole double throw)‡

	"wcd	mbar	"wc	mbar	psi (unless noted)	bar	psi	bar
1	0.7 to 10 "	1,7 to 24,9	0.2 to 1	0,5 to 2,5	30 "Hg Vac to 200	-1,0 to 13,8	400	27,6
2	3 to 20 "	7,5 to 49,8	0.3 to 1.5	0,7 to 3,7	30 "Hg Vac to 200	-1,0 to 13,8	400	27,6
3	10 to 150 "	24,9 to 373,4	0.3 to 5	0,7 to 12,4	30 "Hg Vac to 200	-1,0 to 13,8	400	27,6
	psid	bar	psi	bar (unless noted)	psi (unless noted)	bar	psi	bar
4	2 to 20	0,1 to 1,4	0.3 to 1.5	20,7 to 103,4 mbar	30 "Hg Vac to 1200	-1,0 to 82,7	2500	172,4
5	5 to 80	0,3 to 5,5	1 to 8	0,1 to 0,6	30 "Hg Vac to 1200	-1,0 to 82,7	2500	172,4
6	10 to 150	0,7 to 10,3	1 to 10	0,1 to 0,7	30 "Hg Vac to 1200	-1,0 to 82,7	2500	172,4

Sensor Type K, epoxy coated aluminum pressure housing with Kapton® diaphragm, Buna N sealing diaphragms and 1/8" NPT (female) pressure connections. Non-Belleville actuation. 303/304 stainless steel mounting bracket attached.

DPDT Switch (double pole double throw)‡

	"wcd	mbar	"wc	mbar	psi (unless noted)	bar	psi	bar
1	0.7 to 10 "	1,7 to 24,9	0.2 to 1.5	0,5 to 3,7	30 "Hg Vac to 200	-1,0 to 13,8	400	27,6
2	3 to 20 "	7,5 to 49,8	0.3 to 2	0,7 to 5,0	30 "Hg Vac to 200	-1,0 to 13,84	00	27,6
3	10 to 150 "	24,9 to 373,4	0.3 to 8	0,7 to 19,9	30 "Hg Vac to 200	-1,0 to 13,8	400	27,6
	psid	bar	psi	bar	psi	bar	psi	bar
4	2 to 20	0,1 to 1,4	0.3 to 3	20,7 to 206,8 mbar	30 "Hg Vac to 1200	-1,0 to 82,7	2500	172,4
5	5 to 80	0,3 to 5,5	1 to 10	0,1 to 0,7	30 "Hg Vac to 1200	-1,0 to 82,7	2500	172,4
6	10 to 150	0,7 to 10,3	1 to 15	0,1 to 1,0	30 "Hg Vac to 1200	-1,0 to 82,7	2500	172,4

Temperature Model Chart (Standard capillary: 6ft, #304 st/st)

Model	Adjustable Range		Max. Temperature		Bulb Size
	°F	°C	°F	°C	
R1	-130 to 120	-90 to 48.9	170	76.7	3/8 O.D. x 4 7/8"
R2	0 to 150	-17.8 to 65.6	200	93.3	3/8 O.D. x 7 1/4"
R3	50 to 300	10 to 148.9	350	176.7	3/8 O.D. x 4 7/8"
R4	150 to 650	65.6 to 343.3	700	371.1	3/8 O.D. x 4"

****Proof Pressure:** The maximum pressure to which a pressure sensor may be occasionally subjected, which causes no permanent damage. The unit may require calibration (e.g., start-up, testing)

*****Working Pressure Range:** The pressure range within which two opposing sensors can be safely operated and still maintain set point adjustability.

‡See page 10 on building a part number for switch codes.



12 Series

12 Series

HOW TO ORDER

Step 1: Select letter or number "Codes" to make up a part number

Part #	12	S	H	S	N	2	A	M201
	Series Material	Housing Rating	Electrical Switches	Number of Conduit	Electrical Type	Sensor	Model	Options

(see next page)

ORDERING CODE	DESCRIPTION	12	S	H	S	N	2	A	M201
SERIES 12 DESIGNATION	_____								
12	Designation for Spectra 12 product line								
HOUSING MATERIAL	_____								
S	Stainless Steel								
ELECTRICAL RATING*	_____								
L	1 amp								
H	5 amp								
NUMBER OF SWITCHES	_____								
S	SPDT								
D	DPDT								
ELECTRICAL CONDUIT	_____								
N	1/2" NPT male								
M	M20 metric thread								
SENSOR TYPE, PRESSURE CONNECTION OR BULB & CAPILLARY	_____								
2	Welded 316 stainless steel diaphragm, 1/2" NPT (female) pressure connection								
3	Teflon® coated Polyimide (Kapton®) diaphragm, Buna N O-ring, 1/2" NPT (female) pressure connection								
4	Teflon® coated Polyimide (Kapton®) diaphragm, Buna N O-ring, 1/4" NPT (female) pressure connection								
5	316L stainless steel diaphragm, Viton® O-ring, 1/2" NPT (female) pressure connection								
6	316L stainless steel diaphragm, Viton® O-ring, 1/4" NPT (female) pressure connection								
7	Welded 316L stainless steel diaphragm, 1/2" NPT (female) pressure connection								
8	Kapton® diaphragm, Buna N O-ring, 1/4" NPT (female) pressure connection (non-Belleville actuation)								
9	316L stainless steel welded diaphragm, 1/2" NPT (female) pressure connection (non-Belleville actuation)								
P	303 stainless steel piston, Buna N O-ring, 1/4" NPT (female) pressure connections (non-Belleville actuation)								
K	Kapton® diaphragm, Buna N sealing diaphragm, 1/8" NPT (female) pressure connections (non-Belleville actuation)								
R	Remote bulb & capillary, temperature								

* All switches have limited DC capabilities. Consult factory for details.

MODELS, RANGE

A, B, C, D, E, See model chart for range specifications
 F, G, H, 1, 2,
 3, 4, 5, 6

OPTIONS

- M201 Factory set switch, specify increasing or decreasing pressure
- M277 Range in kPa or mPa on nameplate, factory selected. Not available on temperature versions
- M278 Range in kg/cm² on nameplate. Not available on temperature versions
- M405 European ATEX intrinsic safety compliance
- M406 Russian Gosgortekhnadzor flameproof and intrinsic safety compliance
- M407 CE compliance to Pressure Equipment Directive (category IV). Not available on temperature versions
- M421 Gosgortekhnadzor flameproof junction box, pre-wired (not UL approved or ATEX certified)
- M423 ATEX flameproof compliant junction box, pre-wire (not UL approved)
- M430 Cover lock
- M444 Paper ID tag
- M446 Stainless steel ID tag and wire attachment
- M460 External ground screw; required for non-metallic conduit systems (ATEX installations only)
- M480 316 Stainless steel construction, enclosure and pressure connection(s) only, sensor material cannot be changed. Must order with option code M516 for sensor type P
- M511 1/4" NPT male pressure connection for sensor types 3, 4, 5, 6 and 8 only
- M513 UL approved, explosion proof junction box, pre-wired (not approved for ATEX or as enclosure type 4X). Not available on metric thread electrical conduit version
- M515 DIN Connector-4 terminal; conforms to DIN 43650 Form A, (not approved for Class I Div. 1 & 2 or ATEX flame proof requirements). Not available on DPDT or metric thread electrical conduit versions
- M516 316 Stainless steel 1/4" NPT (female) pressure connection and piston. Available sensor type P only
- M540 Viton® construction (deadband and low end of range will increase slightly); wetted parts include Kapton diaphragm, Viton® O-ring and sealing diaphragm. Available sensor types K and P only
- M550 Oxygen service cleaning; internal construction and materials may change (includes Viton® diaphragm and/or O-ring when applicable). Not available on sensor types 3, 4, and 8
- NC1 NACE certificate

ACCESSORIES

- 62169-13 Mounting bracket kit (available with pressure and temperature models only)
- 62169-31 ATEX flameproof compliant junction box and terminal kit, not pre-wired
- 6361-741 Junction box and terminal kit, not pre-wired (see option code M513 for description)



12 Series

12 Series

OPTIONS FOR TEMPERATURE MODELS

UNION CONNECTORS*

Option	Replacement Number	Description
	<u>304 Stainless Steel</u>	
W028	SD6213-28	1/2" NPT w/ 3/4" bushing
W046	SD6213-46	3/4" NPT
W050	SD6213-50	1/2" NPT

THERMOWELLS

For all bulb & capillary switches

	<u>316 Stainless Steel</u>	
W076	SD6225-76	3/4" NPT, 4.5" BT
W193	SD6225-193	1/2" NPT, 4.5" BT
W119	SD6225-119	3/4" NPT, 7.5" BT
W177	SD6225-177	1/2" NPT, 7.5" BT

OPTIONAL LENGTHS

Optional capillary length to ±50' available in copper or 304 st./st. Armor or Teflon® capillary protection available to lengths less than or equal to capillary length. Consult UE for additional information.

‡Consult UE regarding repeatability and ambient effects on capillary lengths over 30'.

*Dimensional drawings for union connectors and thermowells may be found at www.ueonline.com

DIMENSIONAL DRAWINGS

Dimensional drawings for all models may be found at www.ueonline.com

STANDARD CONFIGURATION

Types	Dimension A		
	Inches	mm	NPT
PRESSURE			
2	4.88	123.9	1/2"
3	4.88	123.9	1/2"
4	4.88	123.9	1/4"
5	4.88	123.9	1/2"
6	4.88	123.9	1/4"
7	5.41	137.5	1/2"
8	4.88	123.9	1/4"
9	5.41	137.5	1/2"
P1-P3	5.38	136.5	1/4"
K1-K3	6.69	169.9	1/8"
K4-K6	6.94	176.2	1/8"
R1-R4	5.00	126.9	N/A

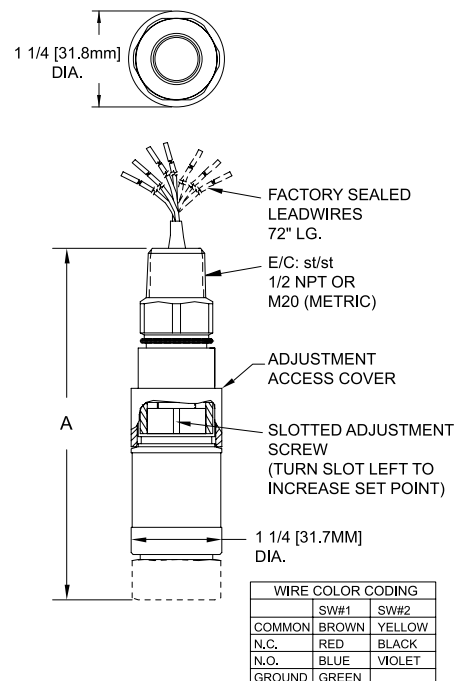

DIMENSIONAL DRAWINGS

Dimensional drawings for all models may be found at www.ueonline.com

SENSOR DETAILS

Pressure

TYPES 2, 3, 5 SENSOR

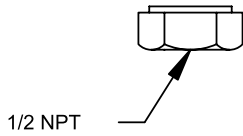

TYPES 4, 6, 8 P1-P3

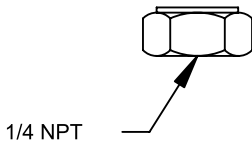

TYPES 7, 9 SENSOR

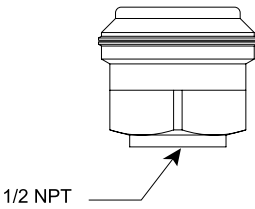

Differential Pressure

TYPE K1-K3*

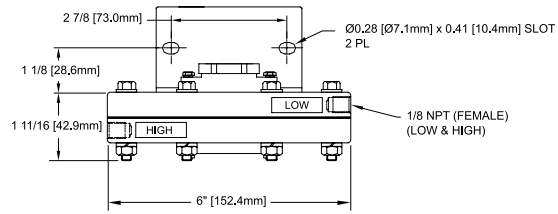

TYPES K4-K6*

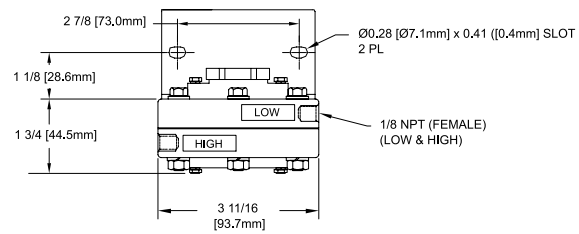

Temperature

TYPES R1-R4

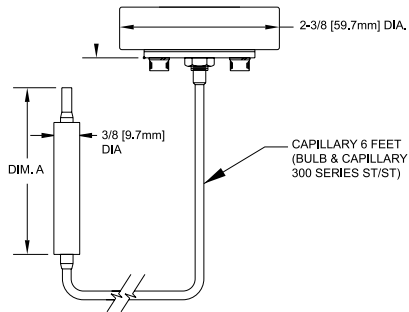

BULB DIMENSIONS		
Dimension A		
Types	Inches	mm
R1	4 7/8"	123.8
R2	7 1/4"	184.2
R3	4 7/8"	123.8
R4	4"	101.6

*Shown with mounting bracket attached

DIMENSIONAL DRAWINGS

Dimensional drawings for all models may be found at www.ueonline.com

**OPTIONAL MOUNTING BRACKET KIT
62169-13**

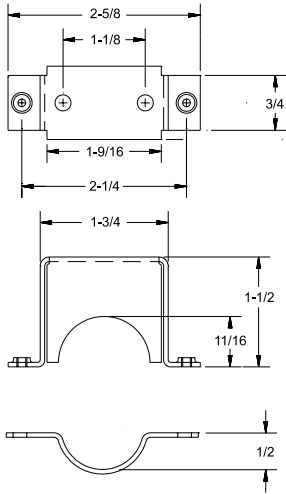

OPTION M423 JUNCTION BOX

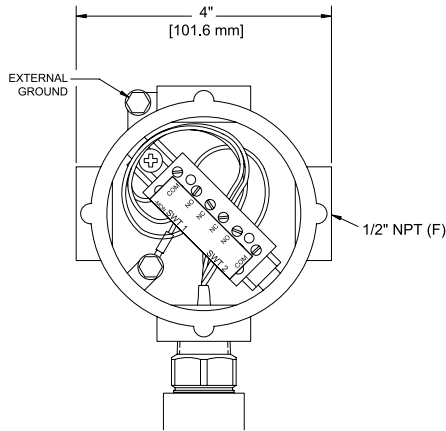

OPTION M430 COVER LOCK

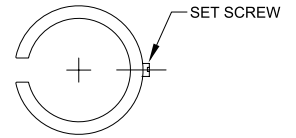

**OPTION M460 EXTERNAL
GROUNDING SCREW**

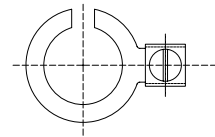

OPTION M513 JUNCTION BOX

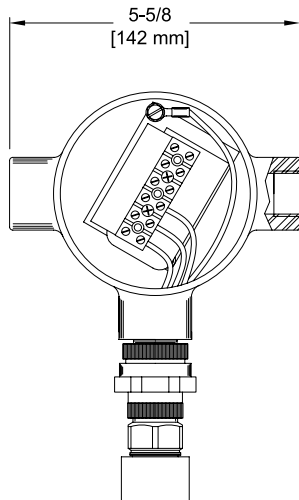

Does not meet ATEX or enclosure type 4X requirements.

OPTION M515 DIN CONNECTOR.

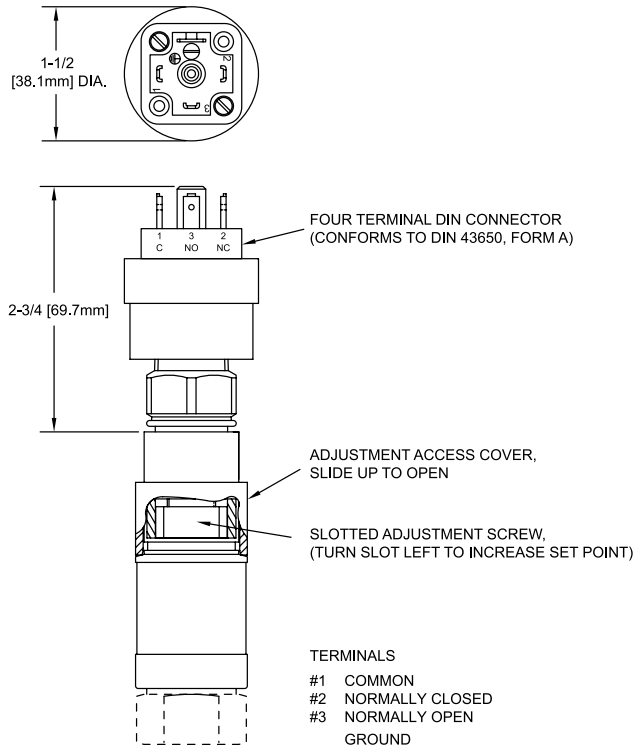

Does not meet Div 1 or 2, or ATEX requirements.

ALTERNATIVE PRODUCTS FROM UE

360 Series Pressure Switches

- Compact, 316 Stainless Steel Housing
- Enclosure type 4X, 7 & 9, IP66
- Hermetically sealed switch
- Pressure ranges 3 to 9,000 psi



120 Series

- Explosion-proof line of pressure, differential pressure, and temperature models with wide selection of ranges, sensors and pressure connections
- UL, cUL, ATEX certified for hazardous locations
- Single or dual switch outputs
- Internal or external set point adjustment



TX200 Series Pressure Transmitters

- Welded, hermetically sealed, 316 Stainless steel construction
- Ranges 0 to 100 psi up to 0 to 24,000 psi
- Choice of field or factory-sealed zero and span calibration
- 4-20 mA or 1-5 VDC output



117 Series

- Single Switch for Corrosive and Hazardous Division 2 Locations
- Compact pressure, differential pressure and temperature models
- Hermetically-sealed SPDT and DPDT output
- Epoxy-coated weather-tight design houses stainless steel internal construction
- Convenient terminal block wiring

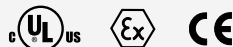

One Series 2-Wire & 4-Wire Electronic Pressure and Temperature Switches with I Am Working Diagnostics Signal

- Solid-state reliability with health-checking diagnostics
- Available with innovative low power "2-Wire" model for discrete input to PLC's or DCS; or models to switch 24-280 VAC @ 10 Amps
- Enclosure type 4X design, approved for Class I, Division 2 hazardous or intrinsically safe locations
- Digital display and tamper-proof keypad adjustment of setpoint and deadband



RECOMMENDED PRACTICES AND WARNINGS

United Electric Controls Company recommends careful consideration of the following factors when specifying and installing UE pressure and temperature units. Before installing a unit, the Installation and Maintenance instructions provided with unit must be read and understood.

- To avoid damaging unit, proof pressure and maximum temperature limits stated in literature and on nameplates must never be exceeded, even by surges in the system. Operation of the unit up to maximum pressure or temperature is acceptable on a limited basis (e.g., start-up, testing) but continuous operation must be restricted to the designated adjustable range. Excessive cycling at maximum pressure or temperature limits could reduce sensor life.
- A back-up unit is necessary for applications where damage to a primary unit could endanger life, limb or property. A high or low limit switch is necessary for applications where a dangerous runaway condition could result.
- The adjustable range must be selected so that incorrect, inadvertent or malicious setting at any range point cannot result in an unsafe system condition.
- Install unit where shock, vibration and ambient temperature fluctuations will not damage unit or affect operation. When applicable, orient unit so that moisture does not enter the enclosure via the electrical connection. When appropriate, this entry point should be sealed to prevent moisture entry.
- Unit must not be altered or modified after shipment. Consult UE if modification is necessary.
- Monitor operation to observe warning signs of possible damage to unit, such as drift in set point or faulty display. Check unit immediately.
- Preventative maintenance and periodic testing is necessary for critical applications where damage could endanger property or personnel.
- Electrical ratings stated in literature and on nameplate must not be exceeded. Overload on a switch can cause damage, even on the first cycle. Wire unit according to local and national electrical codes, using wire size recommended in installation sheet.
- Do not mount unit in ambient temp. exceeding published limits.

LIMITED WARRANTY

Seller warrants that the product hereby purchased is, upon delivery, free from defects in material and workmanship and that any such product which is found to be defective in such workmanship or material will be repaired or replaced by Seller (Ex-works, Factory, Watertown, Massachusetts. INCOTERMS); provided, however, that this warranty applies only to equipment found to be so defective within a period of 36 months from the date of manufacture by the Seller. Seller shall not be obligated under this warranty for alleged defects which examination discloses are due to tampering, misuse, neglect, improper storage, and in any case where products are disassembled by anyone other than authorized Seller's representatives. EXCEPT FOR THE LIMITED WARRANTY OF REPAIR AND REPLACEMENT STATED ABOVE, SELLER DISCLAIMS ALL WARRANTIES WHATSOEVER WITH RESPECT TO THE PRODUCT, INCLUDING ALL IMPLIED WARRANTIES OF MERCHANTABILITY OR FITNESS FOR ANY PARTICULAR PURPOSE.

LIMITATION OF SELLER'S LIABILITY

Seller's liability to Buyer for any loss or claim, including liability incurred in connection with (i) breach of any warranty whatsoever, expressed or implied, (ii) a breach of contract, (iii) a negligent act or acts (or negligent failure to act) committed by Seller, or (iv) an act for which strict liability will be inputed to seller, is limited to the "limited warranty" of repair and/or replacement as so stated in our warranty of product. In no event shall the Seller be liable for any special, indirect, consequential or other damages of a like general nature, including, without limitation, loss of profits or production, or loss or expenses of any nature incurred by the buyer or any third party.

UE specifications subject to change without notice.

U.S. SALES OFFICES

United Electric Controls
32 Highland Rd.
South Hampton, NH 03827
Phone: 603-394-0078
FAX: 603-394-0175

United Electric Controls
28 N. Wise Ave.
Freeport, IL 61032
Phone: 815-235-3501
FAX: 815-235-3847

United Electric Controls
1022 Vineyard Drive
Conyers, GA 30013
Phone: 770-483-8400
FAX: 770-929-8716

United Electric Controls
5829 Grazing Court
Mason, OH 45040
Phone: 513-398-3175
FAX: 513-398-3076

United Electric Controls
102 Salazar Court
Clayton, CA 94517
Phone: 925-524-0210
FAX: 925-524-0210

United Electric Controls
27 Summit Terrace
Sparta, NJ 07871
Phone: 973-271-2550
FAX: 973-729-6099

United Electric Controls
12630 Summerwood Glen
Houston, TX 77041
Phone: 832-243-0119
FAX: 832-243-0140

CANADA

EASTERN
68 Mosley Crescent
Brampton, Ontario
Canada L6Y 5C8
Phone: 905-455-5131
FAX: 905-455-5131

INTERNATIONAL OFFICES

BELGIUM
United Electric Controls-Europe
G. Van Gervenstraat 19A
B-9120 Beveren-Waas, Belgium
Phone: 32-37554-383
FAX: 32-37552-747

CHINA
United Electric Controls
Room 1114, No. 511
Shenshi Building
Weihai Road
Shanghai 200041, P.R. China
Phone: +8621-6255 8059
FAX: +8621-6255 8349

GERMANY
United Electric Controls
An Der Zentlinde 21
D-64711 Erbach, Germany
Phone: 496-062-7400
FAX: 496-062-7501

MALAYSIA
United Electric Controls, Far East
No. 1-2-2, 2nd Floor
Jalan 4/101C
Cheras Business Centre
Batu 5, Jalan Cheras
56100 Kuala Lumpur, Malaysia
Phone: 603-9133-4122
FAX: 603-9133-4155

RUSSIA
United Electric Controls, Moscow
Alyabyeva str., 4-1-4
Moscow, 121309, Russia
Phone: +7 (095) 792-88-06
FAX: +7 (095) 142-34-60

WESTERN
148 Silver Ridge Close N.W.
Calgary, Alberta
Canada T3B 3T4
Phone: 403-247-3724
FAX: 403-247-3724



UNITED ELECTRIC
CONTROLS

180 Dexter Avenue, P.O. Box 9143
Watertown, MA 02471-9143 USA
Telephone: 617 926-1000 Fax: 617 926-2568
<http://www.ueonline.com>

FGS35001204