

# Pneumatic Actuators

Catalog 4123-PA  
Revised, April 2002



# Pneumatic Actuators

## Introduction

Parker 60 Series spring return (AC/AO) or double acting (AD) rack and pinion actuators are compact, simply designed devices that are quality engineered to provide high torque outputs and a high cycle, trouble-free life.

A compact, dual opposed rack and pinion design and guide band suspension combine to produce a symmetrically balanced, center mount actuator. In addition, the actuator has a short powerful stroke, rapid response, and fully concentric operating load capability which ensures optimum performance.

## Features

- Three point suspension system uses carbon filled PTFE guide bands for piston alignment and rack support
- Dual opposed piston design uses air pressure on two pistons to deliver a balanced force to the pinion gear
- Patented balanced piston design results in even distribution of bearing loads and eliminates piston tilting
- Multiple spring concept permits actuator use at 40 to 120 psig (2.8 to 8.3 bar) air supply requirements
- Suitable for use with dry or lubricated air, non-corrosive gas, or light hydraulic oil
- Aluminum alloy body construction with two component polyurethane coating
- Manual override

## Specifications

### Operating Pressure

90° Models:

40 to 120 psig (2.8 to 8.3 bar) maximum

**AC** – Normally Closed Spring Return

**AD** – Double Acting

**AO** – Normally Open Spring Return

180° Models:

80 psig (5.5 bar) maximum

**ACX** – Spring Return

**ADX** – Double Acting

### Temperature Range

-4 °F to 175 °F (-20 °C to 79 °C)

Optional high and low temperature ranges available

## Options

- Solenoid valve
- Rotary limit switch with valve position indicator
- Breather block
- Dual mount actuator

## 61S Option

- Compact single piston design
- Available for MB, HB, B2, and B6 Series Valves

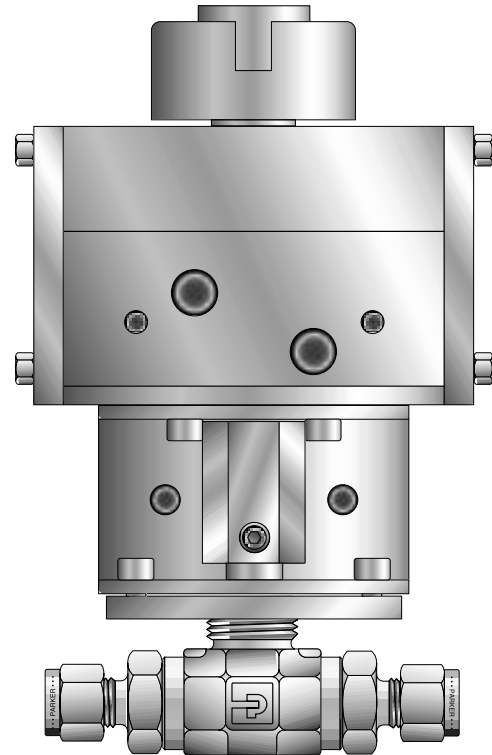

Model Shown: 4Z-B6LJ-V-SS-61AD

## Operation

Actuators are manufactured with an integral air manifold and internal porting. The air manifold is designed for direct mounting of solenoid valves. This eliminates the need for external tubing and simplifies installation. For applications not requiring a solenoid valve, the air manifold inlet ports are marked "A" and "B". Air inlet port "A" will rotate the actuator counter-clockwise. Spring return actuators fail clockwise.

## Dimensional Data for 61 and 61S Models

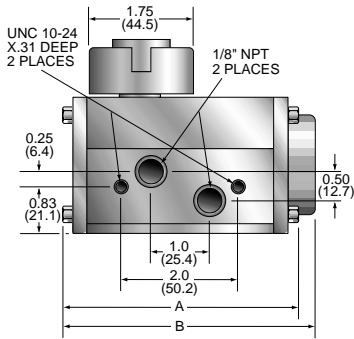

**61S Actuator**

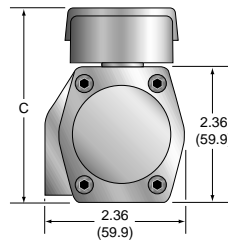

**61 Actuator**

( ) Denotes dimensions in millimeters

Dim	61SAD		61SAC/O		61SADX		61SACX	
	Inch	mm	Inch	mm	Inch	mm	Inch	mm
A	3.37	85.6	-	-	4.63	117.6	-	-
B	-	-	3.66	93.0	-	-	5.83	148.1
C	3.38	85.9	3.38	85.9	3.38	85.9	3.38	85.9

Dim	61AD		61AC/O		61ADX		61ACX	
	Inch	mm	Inch	mm	Inch	mm	Inch	mm
A	4.06	103.1	-	-	6.10	154.9	-	-
B	-	-	4.65	118.1	-	-	8.50	215.9
C1	3.38	85.9	3.38	85.9	3.38	85.9	3.38	85.9
C2	2.36	59.9	2.36	59.9	2.36	59.9	2.36	59.9

C1 – Single Mount C2 – Dual Mount

## Dimensional Data for 62, 63, 64, 65, 66, 68 and 69 Models

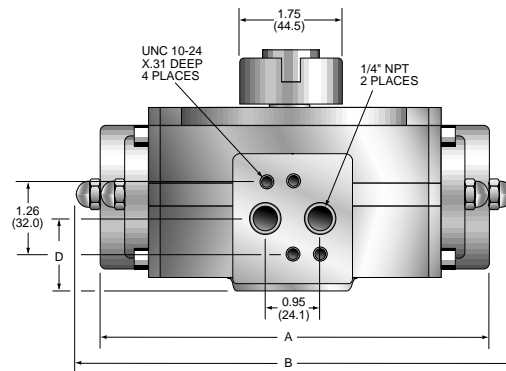
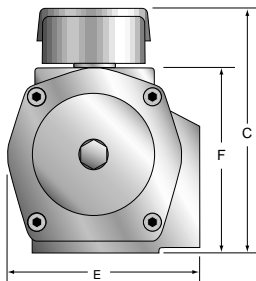

Model	A		B		C				D		E		F	
	Inch	mm	Inch	mm	Single Mount		Dual Mount		Inch	mm	Inch	mm	Inch	mm
					Inch	mm	Inch	mm						
62AD	6.26	159.0	-	-	4.17	105.9	3.15	80.0	1.26	32.0	2.91	73.9	3.15	80.0
62AC/O	-	-	6.77	172.0	4.17	105.9	3.15	80.0	1.26	32.0	2.91	73.9	3.15	80.0
63AD	7.09	180.1	-	-	4.68	118.9	3.86	98.0	1.32	33.5	3.39	86.1	3.66	93.0
63AC/O	-	-	8.03	204.0	4.68	118.9	3.86	98.0	1.32	33.5	3.39	86.1	3.66	93.0
64ADX	6.34	161.0	-	-	5.00	127.0	3.98	101.1	1.69	42.9	4.27	108.5	3.98	101.1
64ACX	-	-	7.17	182.1	5.00	127.0	3.98	101.1	1.69	42.9	4.27	108.5	3.98	101.1
65AD	7.83	198.9	-	-	5.15	130.8	4.13	104.9	1.54	39.1	3.86	98.0	4.13	104.9
65AC/O	-	-	9.8	248.9	5.15	130.8	4.13	104.9	1.54	39.1	3.86	98.0	4.13	104.9
66AD	8.7	221.0	-	-	5.67	144.0	4.65	118.1	1.59	40.4	4.25	108.0	4.65	118.1
66AC/O	-	-	10.51	267.0	5.67	144.0	4.65	118.1	1.59	40.4	4.25	108.0	4.65	118.1
68ADX	7.28	184.9	-	-	6.33	160.8	5.31	134.9	2.09	53.1	5.61	142.5	5.31	134.9
68ACX	-	-	8.5	215.9	6.33	160.8	5.31	134.9	2.09	53.1	5.61	142.5	5.31	134.9
69AD	11.14	283.0	-	-	6.65	168.9	5.63	143.0	1.99	50.5	5.04	128.0	5.63	143.0
69AC/O	-	-	14.17	359.9	6.65	168.9	5.63	143.0	1.99	50.5	5.04	128.0	5.63	143.0

# Pneumatic Actuators

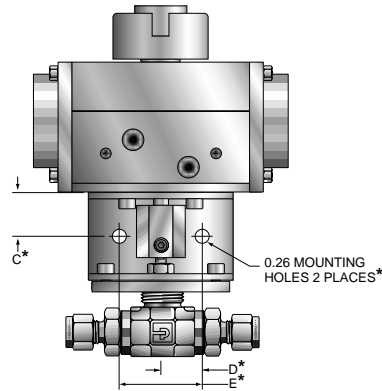
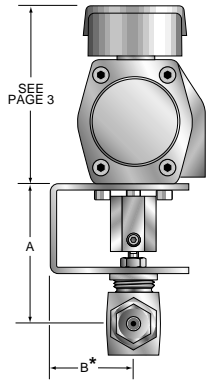

## Valve Dimensional Data

Model Shown: 4Z-B6LJ-V-SS-61AC-2

Valve Series	A		B*		C*		D*		E*	
	Inch	mm	Inch	mm	Inch	mm	Inch	mm	Inch	mm
B2	2.23	56.6								
B6	2.49	63.2								
B8	2.91	73.9								
MB2	2.33	59.2	1.61	40.9	0.80	20.3	0.75	19.1	1.50	38.1
MB4	2.33	59.2								
MB6	2.48	63.0								
HB4	2.70	68.6								
SB8	2.94	74.7								
SB12	3.03	77.0								
SB16	3.27	83.1	N/A	N/A	N/A	N/A	N/A	N/A	N/A	N/A
SB20	3.46	87.9								
SB24	3.73	94.7								
SB32	3.92	99.6								

\*Not applicable for SB Series Ball Valves

## Recommended Actuators for B, MB, and HB Series Ball Valves\*

Valve Series	Double Acting AD	Spring Return AO	Spring Return AC
B2LJ	61AD or 61SAD	61AO-2 or 61SAO	61AC-2 or 61SAC
B2LJ2	61AD or 61SAD	61AO-2 or 61SAO	61AC-2 or R 61SAC
B2XJ	61ADX or 61SADX	61ACX-2 or 61SACX	61ACX-2 or 61SACX
B2XJ2	61ADX or 61SADX	61ACX-2 or 61SACX	61ACX-2 or 61SACX
B6LJ	61AD or 61SAD	61AO-2 or 61SAO	61AC-2 or 61SAC
B6LJ2	61AD or 61SAD	61AO-2 or 61SAO	61AC-2 or 61SAC
B6LS2	61AD or 61SAD	61AO-2 or 61SAO	61AC-2 or 61SAC
B6LPKR	61AD or 61SAD	61AO-2 or 61SAO	61AC-2 or 61SAC
B6LSPKR	61AD or 61SAD	61AO-2 or 61SAO	61AC-2 or 61SAC
B6XJ	61ADX or 61SADX	61ACX-2 or 61SACX	61ACX-2 or 61SACX
B6XJ2	61ADX or 61SADX	61ACX-2 or 61SACX	61ACX-2 or 61SACX
B6XS2	61ADX or 61SADX	61ACX-2 or 61SACX	61ACX-2 or 61SACX
B6XPKR	61ADX or 61SADX	61ACX-2 or 61SACX	61ACX-2 or 61SACX
B6XSPKR	61ADX or 61SADX	61ACX-2 or 61SACX	61ACX-2 or 61SACX
B8LJ	61AD	61AO-2	61AC-2
B8LJ2	61AD	62AO-3	62AC-3
B8LS2	61AD	62AO-3	62AC-3
B8LPKR	61AD	62AO-3	62AC-3
B8XJ	61ADX	61ACX-2	61ACX-2
B8XJ2	61ADX	64ACX-12	64ACX-12
B8XS2	61ADX	64ACX-12	64ACX-12
B8XPKR	61ADX	64ACX-12	64ACX-12
HB4LPKR	61AD	62AO-3	62AC-3
HB4LK	61AD	61AO-2	61AC-2
HB4XPKR	61ADX	64ACX-8	64ACX-8
HB4XK	61ADX	61ACX-2	61ACX-2
MB2A	61AD or 61SAD	61AO-2 or 61SAO	61AC-2 or 61SAC
MB2L	61AD or 61SAD	61AO-2 or 61SAO	61AC-2 or 61SAC
MB2X	61ADX or 61SADX	61ACX-2 or 61SACX	61ACX-2 or 61SACX
MB4A	61AD or 61SAD	61AO-2 or 61SAO	61AC-2 or 61SAC
MB4L	61AD or 61SAD	61AO-2 or 61SAO	61AC-2 or 61SAC
MB4X	61ADX or 61SADX	61ACX-2 or 61SACX	61ACX-2 or 61SACX
MB6A	61AD or 61SAD	61AO-2 or 61SAO	61AC-2 or 61SAC
MB6L	61AD or 61SAD	61AO-2 or 61SAO	61AC-2 or 61SAC
MB6X	61ADX or 61SADX	61ACX-2 or 61SACX	61ACX-2 or 61SACX

\*With 60 psig (4.1 bar) actuation pressure

## Suggested Actuators for SB Series Ball Valves

Actuators were sized in this table using the maximum allowable pressure differential across the seats with a 1.20 multiplier for application factor. Please determine, by reading page 6, if the media or service conditions would render the information in this table questionable. Actuators for SB Series Ball Valves may also be downsized to fit the application using the technique found on page 6.

Two-way Valves SBL					Three-way Diverter Valves SBXD					Three-way Selector Valves SBX				
Valve Size	Double Acting AD		Spring Return AC/AO		Valve Size	Double Acting AD		Spring Return AC		Valve Size	Double Acting AD		Spring Return AC	
	60 psig (4.1 bar)	80 psig (5.5 bar)	60 psig (4.1 bar)	80 psig (5.5 bar)		60 psig (4.1 bar)	80 psig (5.5 bar)	60 psig (4.1 bar)	80 psig (5.5 bar)		60 psig (4.1 bar)	80 psig (5.5 bar)	60 psig (4.1 bar)	80 psig (5.5 bar)
<b>T Seats</b>					<b>T Seats</b>					<b>T Seats</b>				
SB8	61AD	61AD	62AC-3	61AC-2	SB8	61ADX	61ADX	64ACX-8	61ACX-2	SB8	61ADX	61ADX	64ACX-8	64ACX-8
SB12	61AD	61AD	62AC-3	61AC-2	SB12	61ADX	61ADX	64ACX-8	61ACX-2	SB12	61ADX	61ADX	68ACX-8	64ACX-12
SB16	62AD	61AD	63AC-3	63AC-3	SB16	64ADX	61ADX	64ACX-8	68ACX-2	SB16	64ADX	61ADX	68ACX-8	68ACX-8
SB20	62AD	62AD	65AC-3	63AC-4										
SB24	63AD	62AD	66AC-3	65AC-4	SB24	64ADX	64ADX	-	68ACX-12	SB24	68ADX	64ADX	*	*
SB32	63AD	63AD	69AC-3	66AC-4	SB32	68ADX	68ADX	*	*	SB32	68ADX	68ADX	*	*
<b>RT Seats</b>					<b>RT Seats</b>									
SB8	61AD	61AD	62AC-3	61AC-2	SB8	61ADX	61ADX	64ACX-8	61ACX-2					
SB12	61AD	61AD	62AC-3	62AC-3	SB12	61ADX	61ADX	64ACX-8	64ACX-8					
SB16	62AD	61AD	63AC-3	63AC-3	SB16	61ADX	61ADX	68ACX-8	68ACX-8					
SB20	63AD	63AD	69AC-3	66AC-4										
SB24	63AD	63AD	69AC-3	66AC-4	SB24	68ADX	68ADX	*	*					
SB32	66AD	65AD	69AC-3	69AC-3	SB32	-	68ADX	*	*					
<b>PF Seats</b>					<b>PF Seats</b>					<b>PF Seats</b>				
SB8	61AD	61AD	62AC-3	61AC-2	SB8	61ADX	61ADX	64ACX-8	61ACX-2	SB8	61ADX	61ADX	68ACX-8	64ACX-12
SB12	61AD	61AD	62AC-3	62AC-3	SB12	61ADX	61ADX	64ACX-8	64ACX-8	SB12	64ADX	61ADX	68ACX-8	68ACX-8
SB16	62AD	61AD	63AC-3	63AC-3	SB16	64ADX	64ADX	68ACX-8	68ACX-12	SB16	64ADX	64ADX	-	68ACX-12
SB20	63AD	62AD	66AC-3	64AC-4										
SB24	63AD	63AD	66AC-3	66AC-3	SB24	68ADX	64ADX	*	*	SB24	68ADX	68ADX	*	*
SB32	66AD	65AD	69AC-3	69AC-3	SB32	68ADX	68ADX	*	*	SB32	-	68ADX	*	*
<b>PKP Seats</b>					<b>PKP Seats</b>									
SB8	61AD	61AD	63AC-3	63AC-4	SB8	61ADX	61ADX	68ACX-8	64ACX-12					
SB12	63AD	62AD	66AC-3	65AC-4	SB12	64ADX	64ADX	68ACX-10	68ACX-10					
SB16	63AD	63AD	69AC-3	66AC-4	SB16	68ADX	68ADX	*	*					
SB20	65AD	63AD	69AC-3	69AC-4										
SB24	66AD	65AD	69AC-3	69AC-4	SB24	68ADX	68ADX	*	*					
SB32	69AD	66AD	-	69AC-4	SB32	*	*	*	*					
<b>UPE Seats</b>					<b>UPE Seats</b>					<b>UPE Seats</b>				
SB8	61AD	61AD	62AC-3	62AC-3	SB8	61ADX	61ADX	64ACX-8	64ACX-8	SB8	61ADX	61ADX	68ACX-8	64ACX-10
SB12	61AD	61AD	63AC-3	62AC-4	SB12	61ADX	61ADX	64ACX-8	64ACX-8	SB12	64ADX	61ADX	68ACX-8	68ACX-8
SB16	62AD	62AD	65AC-3	63AC-4	SB16	64ADX	61ADX	68ACX-8	68ACX-8	SB16	64ADX	64ADX	68ACX-10	68ACX-10
SB20	62AD	62AD	65AC-3	64AC-4										
SB24	63AD	62AD	66AC-3	65AC-4	SB24	64ADX	64ADX	-	68ACX-12	SB24	68ADX	68ADX	*	*
SB32	63AD	63AD	69AC-4	66AC-4	SB32	68ADX	64ADX	-	68ACX-12	SB24	68ADX	68ADX	*	*
<b>DE Seats</b>					<b>DE Seats</b>									
SB8	61AD	61AD	63AC-3	63AC-3	SB8	61ADX	61ADX	68ACX-8	64ACX-12					
SB12	62AD	61AD	63AC-3	63AC-3	SB12	64ADX	61ADX	68ACX-8	64ACX-12					
SB16	62AD	61AD	65AC-3	63AC-4	SB16	64ADX	61ADX	68ACX-8	68ACX-8					
SB20	65AD	63AD	69AC-3	66AC-4										
SB24	66AD	65AD	69AC-3	69AC-4	SB24	68ADX	68ADX	*	*					
SB32	69AD	66AD	-	69AC-4	SB32	*	*	*	*					

\* Consult the factory for methods to actuate these valves.

## Determination of Valve Torque

By properly sizing an actuator to a valve for a specific application, performance is guaranteed and economies are gained. Before an actuator can be sized for an application, the amount of torque required must be determined. The operating torque of a ball valve is influenced by the design, seat material, and application (service) conditions.

Stem torque is primarily dependent upon the tightness of the stem nut. The design of the SB Series Ball Valve is such that the stem torque is constant. Ball/seat torque is created by the friction between the ball and seat and is also very sensitive to service conditions. The “floating ball” design concept allows the system pressure to force the ball into the downstream seat. The higher the system pressure, the harder the ball is forced into the downstream seat, and, therefore, the higher the torque. Also, since different seat materials have different coefficients of friction, the ball/seat torque also becomes a function of the seat material being used.

Valve torque is also a function of the media flowing through the valve. Abrasive medias have a tendency to increase the amount of friction between the ball and seats, whereas some light oils, which provide additional lubricity, may reduce the amount of torque required.

The pressure torque curves on page 7 are the result of laboratory testing using water at ambient temperature as the medium. Torque values derived from these curves, when the appropriate service condition correction factors are applied, will be adequate for the vast majority of applications.

Based upon the valve size, seat material, and differential pressure across the valve (in the closed position), the amount of torque required may be determined using the following procedure:

1. Find the valve torque from the appropriate curve by using the differential pressure. Locate the differential pressure on the horizontal axis of the chart and move up until you arrive at the appropriate valve size. Transfer the intersecting point across to the vertical axis of the graph and read the required torque.
2. Multiply this torque by the service and media application factor multipliers. The maximum combined multiplier should never be greater than 2.

### Application Factor

### Multiplier

#### A. Service

On-Off	1.00
Emergency shutdown (cycled less than once per month)	2.00
Applications with less than two cycles per day	1.20
Applications below -20 °F (-29 °C)	1.25

#### B. Media

Saturated steam	1.20
Clean saturated steam	1.00
Liquid, clean (particle free)	1.00
Liquid, dirty (slurry), raw water	1.80
Gas, clean and wet	1.20
Gas, clean and dry (superheated stm.)	1.00
Gas, dirty (natural gas)	1.50
Chlorine	1.50

## Actuator Selection

When the torque requirements have been determined, the actuator may be properly sized.

### 1. Double Acting Operation (AD)

Select the actuator whose torque output, at the minimum air supply pressure, **exceeds** the calculated torque. Actuator torque output charts are shown on pages 8 and 9.

### 2. Spring Return Operation, Fail Closed (AC)

Select the actuator whose spring torque output **exceeds** the calculated torque. Actuator torque output charts are shown on pages 8 and 9. In addition, check the selected actuator to insure the air torque output at the minimum air supply pressure **also exceeds** the calculated torque.

### 3. Spring Return Operation, Fail Open (AO)

Select the actuator whose spring torque output **exceeds** the calculated torque. Actuator torque output charts are shown on pages 8 and 9. In addition, check the selected actuator to insure the air torque output at the minimum air supply pressure **also exceeds** the calculated torque.

**SB Series Pressure Torque Curves:  
Two-way (L) and Three-way (XD) Diverter Valves**

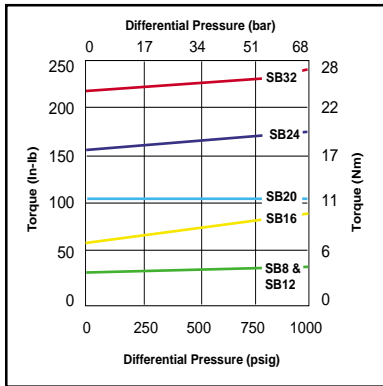

**T Seats**

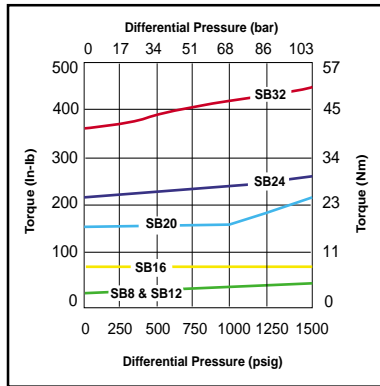

**RT Seats**

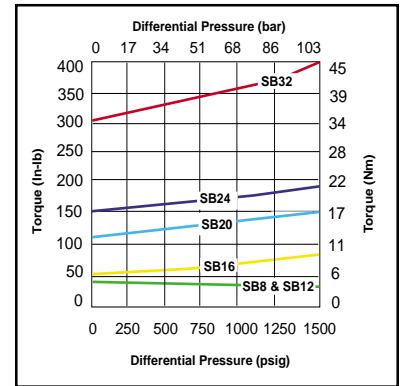

**PF Seats**

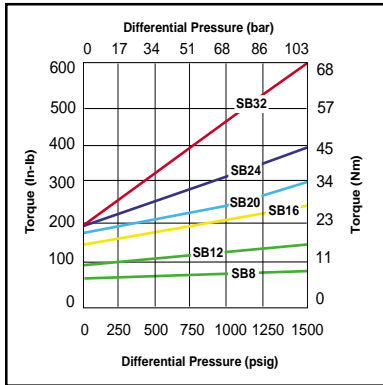

**PKP Seats**

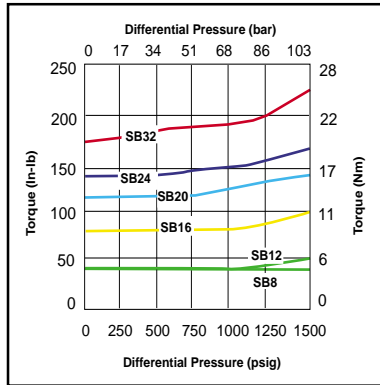

**UPE Seats**

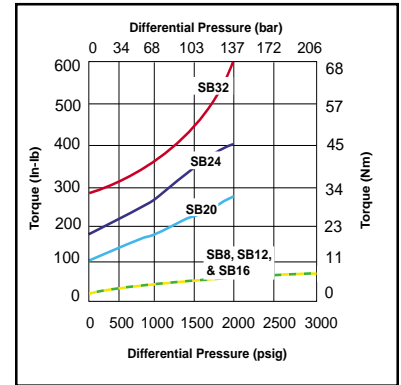

**DE Seats**

**SB Series Pressure Torque Curves: Three-way (X) Selector Valves**

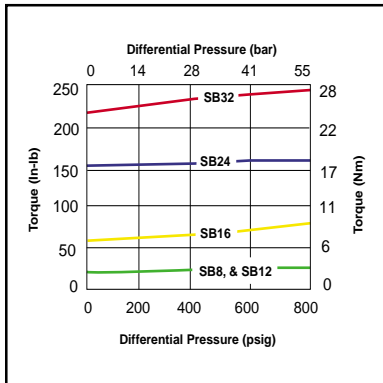

**T Seats**

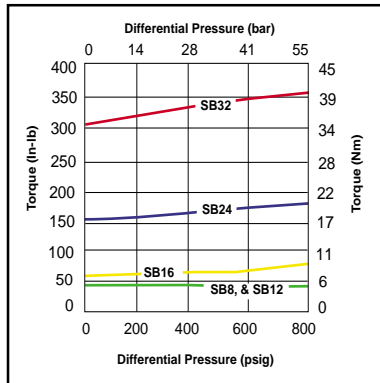

**PF Seats**

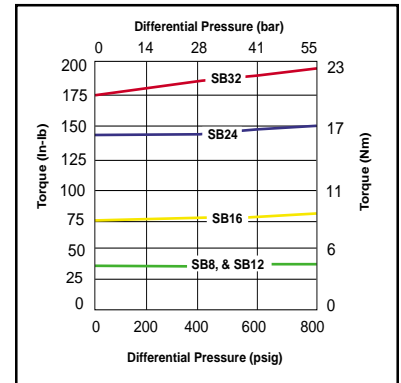

**UPE Seats**

# Pneumatic Actuators

## 90° Models (AC, AO, and AD)

### Performance Characteristics

Series	Bore		Stroke		Weight				Operating Time	Air Consumption		Air Consumption	
					AD		AC/AO			in <sup>3</sup>		cc	
	Inch	mm	Inch	mm	lb	kg	lb	kg	sec	Port "A"	Port "B"+	Port "A"	Port "B"+
61	1.8	45.7	0.5	12.7	1.3	0.6	1.5	0.7	0.4	3.1	3.7	50.8	60.7
61S	1.8	45.7	0.5	12.7	1.2	0.5	1.2	0.6	0.4	2.4	1.2	39.3	19.7
62	2.2	55.9	0.6	15.2	2.9	1.3	3.7	1.7	0.5	6.1	6.7	100.0	109.8
63	2.8	71.1	0.7	17.8	4.0	1.8	5.3	2.4	0.7	9.8	13.4	160.7	219.7
65	3.1	78.7	0.9	22.1	5.3	2.4	7.9	3.6	1.1	20.1	22.0	329.5	360.7
66	3.6	91.4	1.0	25.4	6.8	3.1	10.1	4.6	1.2	21.4	29.9	350.8	490.2
69	4.3	109.2	1.5	38.1	12.8	5.8	20.1	9.1	2.3	49.0	61.0	803.3	1000.0

+Double acting only

### AD Torques

Series	40 psig (2.8 bar)		60 psig (4.1 bar)		80 psig (5.5 bar)		100 psig (6.9 bar)	
	in-lb	Nm	in-lb	Nm	in-lb	Nm	in-lb	Nm
61	59	6.7	89	10.1	119	13.4	149	16.8
61S	-	-	45	5.1	59	6.7	75	8.5
62	109	12.3	165	18.6	220	24.9	276	31.2
63	205	23.2	309	34.9	413	46.7	518	58.5
65	312	35.2	471	53.2	630	71.2	789	89.1
66	461	52.1	696	78.6	930	105.1	1165	131.6
69	1011	114.2	1527	172.5	2042	230.7	2557	288.9

### AC and AO Torques

Series	Spring Set	Air Torque								Spring Torque	
		40 psig (2.8 bar)		60 psig (4.1 bar)		80 psig (5.5 bar)		100 psig (6.9 bar)			
		in-lb	Nm	in-lb	Nm	in-lb	Nm	in-lb	Nm	in-lb	Nm
61	2	-	-	23	2.6	55	6.2	87	9.8	41	4.6
61S	-	-	-	16	1.8	21	2.4	26	2.9	21	2.4
62	2	44	5.0	103	11.6	162	18.3	220	24.9	39	4.4
	3	8	0.9	66	7.5	126	14.2	185	20.9	58	6.6
	4	-	-	31	3.5	90	10.2	149	16.8	78	8.8
	5	-	-	-	-	54	6.1	113	12.8	98	11.1
	6	-	-	-	-	18	2.0	77	8.7	117	13.2
63	2	82	9.3	193	21.8	304	34.3	413	46.7	74	8.4
	3	15	1.7	126	14.2	236	26.7	346	39.1	110	12.4
	4	-	-	58	6.6	169	19.1	279	31.5	146	16.5
	5	-	-	-	-	101	11.4	212	24.0	183	20.7
	6	-	-	-	-	34	3.8	144	16.3	220	24.9
65	2	117	13.2	285	32.2	453	51.2	622	70.3	117	13.2
	3	10	1.1	178	20.1	347	39.2	515	58.2	175	19.8
	4	-	-	72	8.1	240	27.1	408	46.1	234	26.4
	5	-	-	-	-	133	15.0	301	34.0	292	33.0
	6	-	-	-	-	26	2.9	195	22.0	351	39.7
66	2	192	21.7	441	49.8	690	78.0	939	106.1	161	18.2
	3	43	4.9	293	33.1	542	61.2	790	89.3	242	27.3
	4	-	-	143	16.2	392	44.3	641	72.4	323	36.5
	5	-	-	-	-	244	27.6	492	55.6	403	45.5
	6	-	-	-	-	95	10.7	344	38.9	484	54.7
69	2	406	45.9	952	107.6	1498	169.2	2043	230.8	361	40.8
	3	73	8.2	620	70.0	1165	131.6	1711	193.3	543	61.3
	4	-	-	287	32.4	833	94.1	1378	155.7	723	81.7
	5	-	-	-	-	500	56.5	1045	118.1	904	102.1
	6	-	-	-	-	167	18.9	713	80.6	1085	122.6

## 180° Models (ACX AND ADX)

### Performance Characteristics

Series	Bore		Stroke		Weight				Operating Time sec	Air Consumption in <sup>3</sup>		Air Consumption cc	
	Inch	mm	Inch	mm	AD		AC			Port "A"	Port "B"+	Port "A"	Port "B"+
					lb	kg	lb	kg					
61	1.8	45.7	1.0	25.4	1.9	0.9	2.4	1.1	0.8	4.5	5.7	73.8	93.4
61S	1.8	45.7	1.0	25.4	1.4	0.7	1.7	0.8	0.8	6.1	3.1	100.0	50.0
64	3.2	81.3	0.7	17.8	5.5	2.5	6.4	2.9	1.5	16.0	23.0	262.3	377.0
68	4.3	109.2	1.0	25.4	11.6	5.3	13.6	6.2	2.8	37.0	49.0	606.6	803.3

+Double acting only

### ADX Torques

Series	40 psig (2.8 bar)		60 psig (4.1 bar)		80 psig (5.5 bar)	
	in-lb	Nm	in-lb	Nm	in-lb	Nm
61	59	6.7	89	10.1	119	13.4
61S	-	-	45	5.1	59	6.7
64	139	15.7	210	23.7	281	31.7
68	351	39.7	530	59.9	709	80.1

### ACX Torques

Series	Spring Set	Air Torque						Spring Torque	
		40 psig (2.8 bar)		60 psig (4.1 bar)		80 psig (5.5 bar)		in-lb	Nm
		in-lb	Nm	in-lb	Nm	in-lb	Nm		
61	2	-	-	25	2.8	57	6.4	39	4.4
61S	-	-	-	16	1.8	21	2.4	21	2.4
64	8	19	2.1	90	10.2	161	18.2	62	7.0
	10	-	-	60	6.8	131	14.8	78	8.8
	12	-	-	30	3.4	101	11.4	93	10.5
	14	-	-	-	-	71	8.0	109	12.3
68	8	76	8.6	255	28.8	433	48.9	150	16.9
	10	-	-	186	21.0	365	41.2	187	21.1
	12	-	-	117	13.2	296	33.4	225	25.4
	14	-	-	48	5.4	227	25.6	262	29.6

# Pneumatic Actuators

## SB Series Actuator Sizing Examples

### EXAMPLE 1

Valve Desired: 24Z-SB24L-PF-T-SS  
Actuator Desired: Spring Return, Normally Closed  
Differential Pressure: 250 psig  
Minimum Air Supply Pressure: 80 psig  
Service: On-off  
Media: Raw Water

#### Calculation

From the PF Seal Pressure-Torque graph on page 7:

Torque at 250 psig = 170 in-lb

Service Factor from page 6:

Multiplier = 1.00

Media Factor from page 6:

Multiplier = 1.80

Application Operating Torque =

Operating Torque x Application Factor =  
170 in-lb x 1.00 x 1.80 = 306 in-lb

From the AC Spring Torques on page 8, proceed down the table looking for a torque exceeding 306 in-lb. The 65AC-6 meets the requirement, but the Air Torque at 80 psig does not. Repeat this step to find a larger actuator. The next actuator in the table to meet both requirements is the 66AC-4.

Valve Model: 24Z-SB24L-PF-T-SS-66AC-4

### EXAMPLE 2

Valve Desired: 12A-SB12L-T-SS  
Actuator Desired: Spring Return, Normally Open  
Differential Pressure: 400 psig  
Minimum Air Supply Pressure: 60 psig  
Service: -20 °F  
Media: Dirty Gas

#### Calculation

From the T Seal Pressure-Torque graph on page 7:

Torque at 400 psig = 30 in-lb

Service Factor from page 6:

Multiplier = 1.25

Media Factor from page 6:

Multiplier = 1.50

Application Operating Torque =

Operating Torque x Application Factor =  
30 in-lb x 1.25 x 1.50 = 57 in-lb

From the AC Spring Torques on page 8, proceed down the table looking for a torque exceeding 57 in-lb. The 62AO-3 meets the requirement for both Spring Torque and Air Torque.

Valve Model: 12A-SB12L-T-SS-62AO-3

## How to Order Actuators

### Factory Assembled

Add the actuator model designation as a suffix to the ball valve part number.

Example: **4Z-B6LJ2-SS-61AC-2**. Describes a B6 ball valve with a normally closed actuator.

### For Field Assembly

Simply specify the actuator. Example: **65AC-3**. Mounting bracket kits are required when mounting actuators to valves.

### With Mounting Brackets

Specify the ball valve series and seat material followed by the actuator. Examples: **B6LJ-61AO-2**, **MB6XPFA-61ACX**, **SB12LRT-62AC-3**.

## Options

**High Temperature Seals** – Extends the high temperature from 175 °F (79 °C) to 250 °F (121 °C) and to 400 °F (204 °C) on special Series 62 and 63 90° models.

**Low Temperature Seals** – Extends the low temperature from -4 °F (-20 °C) to -40 °F (-40 °C).

**Solenoid Valve** (Single coil) – Mounts directly to the actuator inlet manifold. NEMA 4 or 7 housings with voltages of 24 VDC, 120 VAC, and 240 VAC. A manual override is standard.

**Limit Switch** – Rugged, fully enclosed unit contains two SPDT snap-acting switches operated by two independently adjustable cams on a rotating shaft coupled directly to the actuator auxiliary drive. Features a visual valve position indicator. Meets NEMA 4, 7, and 9 classifications for weather-resistant and hazardous locations.

**Breather Block** – A direct mount diverter module redirects instrument quality air to the spring chamber during the spring stroke (fail stroke) of AC and AO actuators. Ideal for corrosive, wet, or dusty environments. Also improves spring stroke speed and allows the solenoid valve to be mounted to it.

**Dual Mount Actuator** – Two valves may be actuated with a single actuator. Available with both valves open, both closed, or one open and one closed.

**NOTE:** Parker pneumatically actuated B Series Ball Valves should be ordered with elastometric stem packing and seals or the optional live-loaded PTFE packing. This reduces the need for any further packing adjustment after receipt from the factory.

## How to Order Options

**High Temperature Seals** – Add the suffix **–HT** to the end of the part number for service up to 250 °F (121 °C). Add the suffix **–HT4** to the end of the part number for service up to 400 °F (204 °C). **NOTE:** The **–HT4** option is only available on series 62 and 63 90° models. Example: 2F-HB4LK-BN-SS-61AD-**HT**.

**Low Temperature Seals** – Add the suffix **–LT** to the end of the part number. Example: 4A-MB4LPFA-SS-61SAC-**LT**.

**Accessories** – Add one of the following suffixes to the end of the part number. Example: 16F-SB16L-PF-T-SS-63AC-3-**2D**.

Suffix	Accessory
<b>Single Option</b>	
-1A	Breather Block
-1B	Solenoid Valve, (NEMA 4, 120 VAC)
-1C	Solenoid Valve, (NEMA 7, 120 VAC)
-1D	Solenoid Valve, (NEMA 4, 24 VDC)
-1E	Solenoid Valve, (NEMA 7, 24 VDC)
-1F	Solenoid Valve, (NEMA 4, 240 VAC)
-1G	Solenoid Valve, (NEMA 7, 240 VAC)
-1H	Limit Switch – Two SPDT switches with mounting kit
<b>Double Option</b>	
-2A	Breather Block, Solenoid Valve, (NEMA 4, 120 VAC)
-2B	Breather Block, Solenoid Valve, (NEMA 7, 120 VAC)
-2C	Breather Block, Solenoid Valve, (NEMA 4, 24 VDC)
-2D	Breather Block, Solenoid Valve, (NEMA 7, 24 VDC)
-2E	Breather Block, Solenoid Valve, (NEMA 4, 240 VAC)
-2F	Breather Block, Solenoid Valve, (NEMA 7, 240 VAC)
-2G	Limit Switch, Solenoid Valve, (NEMA 4, 120 VAC)
-2H	Limit Switch, Solenoid Valve, (NEMA 7, 120 VAC)
-2J	Limit Switch, Solenoid Valve, (NEMA 4, 24 VDC)
-2K	Limit Switch, Solenoid Valve, (NEMA 7, 24 VDC)
-2L	Limit Switch, Solenoid Valve, (NEMA 4, 240 VAC)
-2M	Limit Switch, Solenoid Valve, (NEMA 7, 240 VAC)
<b>Triple Option</b>	
-3A	Breather Block, Limit Switch, Solenoid Valve, (NEMA 4, 120 VAC)
-3B	Breather Block, Limit Switch, Solenoid Valve, (NEMA 7, 120 VAC)
-3C	Breather Block, Limit Switch, Solenoid Valve, (NEMA 4, 24 VDC)
-3D	Breather Block, Limit Switch, Solenoid Valve, (NEMA 7, 24 VDC)
-3E	Breather Block, Limit Switch, Solenoid Valve, (NEMA 4, 240 VAC)
-3F	Breather Block, Limit Switch, Solenoid Valve, (NEMA 7, 240 VAC)

**Dual Mount Actuator** – Add **–DVM** as a suffix to the end of the part number. Example: 6F-B6LPKC-SS-61AC-2-**DVM**. With **DVM** dual mount valve options, the following are standard arrangements: Two-way valves are provided in their failed position (in their closed position with AD actuators). Three-way valves are provided as shown below. Contact the factory for details on other available options.

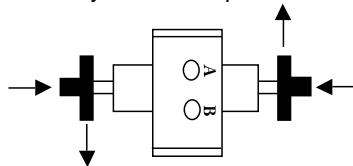

## How to Order Mounting Bracket Kits

Add the valve series and actuator model designation as a suffix to **MK-**. Example: MK-**MB4L-61S**. Describes a mounting kit for a MB Series ball valve with a 61S Series actuator.

### **WARNING**

FAILURE, IMPROPER SELECTION OR IMPROPER USE OF THE PRODUCTS AND/OR SYSTEMS DESCRIBED HEREIN OR RELATED ITEMS CAN CAUSE DEATH, PERSONAL INJURY AND PROPERTY DAMAGE.

This document and other information from Parker Hannifin Corporation, its subsidiaries and authorized distributors provide product and/or system options for further investigation by users having technical expertise. It is important that you analyze all aspects of your application and review the information concerning the product or system in the current product catalog. Due to the variety of operating conditions and applications for these products or systems, the user, through its own analysis and testing, is solely responsible for making the final selection of the products and systems and assuring that all performance, safety and warning requirements of the application are met.

The products described herein, including without limitation, product features, specifications, designs, availability and pricing, are subject to change by Parker Hannifin Corporation and its subsidiaries at any time without notice.

### **Offer of Sale**

The items described in this document are hereby offered for sale by Parker Hannifin Corporation, its subsidiaries or its authorized distributors. This offer and its acceptance are governed by the provisions stated in the "Offer of Sale" located in Catalog 4110-U Needle Valves (U Series).



---

**Parker Hannifin Corporation**  
Instrumentation Valve Division  
2651 Alabama Highway 21 North  
Jacksonville, AL 36265-9681  
USA  
Phone: (256) 435-2130  
Fax: (256) 435-7718  
[www.parker.com/IVD](http://www.parker.com/IVD)



**Parker Hannifin plc**  
Instrumentation Products Division  
Riverside Road  
Pottington Business Park  
Barnstaple, Devon EX31 1NP  
England  
Phone: +44 (0) 1271 313131  
Fax: +44 (0) 1271 373636  
Email: [ipd@parker.com](mailto:ipd@parker.com)  
[www.parker.com/IPD](http://www.parker.com/IPD)

