

Ball Valves (MB Series)

*Catalog 4121-MB
Revised, June 2001*



MB Series Ball Valves

Introduction

Parker MB Series Ball Valves, with their rugged compact design, offer positive shut off or directional control of fluids in process, power and instrumentation applications. The unique one piece seat/packing design insures excellent sealing characteristics while accommodating a superior temperature range and cycle life.

These valves are available in 2-way and 3-way configurations, brass and stainless steel construction, with a wide variety of port connections. Also, all ports are suitable as inlets to full operating pressure of the valve.

Features

- One piece seat/packing design
- Broad temperature range
- Coated metal inserts
- One piece stem/ball
- Wide variety of US Customary and SI ports
- Panel mountable to 1/4" thickness
- Bi-directional flow
- Handle indicates direction of flow
- Full operating pressure at any port
- Positive handle stops
- Color coded handles
- 100% factory tested
- Optional upstream or downstream (default) vent
- Manual, electric or pneumatic actuation
- Leak-tight center-off position on 3-way valves

Specifications

- Pressure rating: 3000 psig* (207 bar) CWP - MB6
2500 psig* (172 bar) CWP - MB2/MB4
- Temperature rating: -65 °F to 300 °F (-54 °C to 149 °C)
- Orifice: .052" to .187" (1.3 mm to 4.7 mm)
- C_v : .05 to 1.08
- Body materials: Stainless Steel and Brass
- Body configurations: 2-way (in-line and angle) and 3-way
- Port connections: Tube compression (CPI™ / A-LOK®)
NPT (Male / Female)
BSP, VacuSeal and UltraSeal
- Port size: 1/16" to 3/8" and 3mm to 8mm
- Seat/Packing: PFA-Perfluoroalkoxy

*Preset from factory to 1000 psig (69 bar) bubble tight service. Packing nut must be tightened to achieve higher pressures. Packing in vented MB Series Ball Valves is factory adjusted for the maximum valve pressure rating of 500 psig (34 bar).

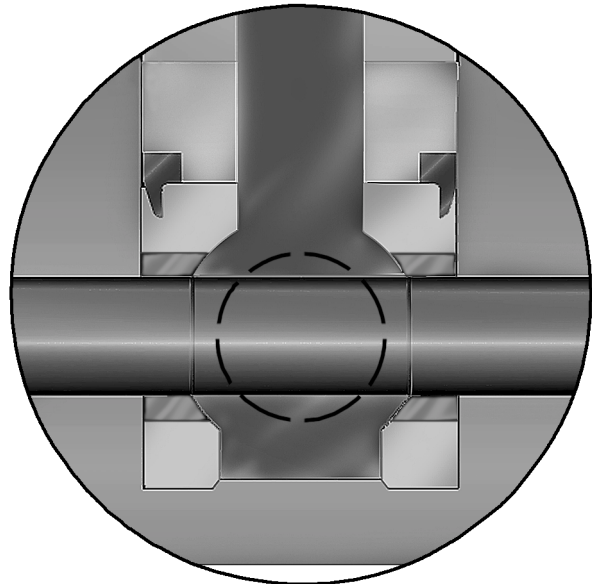
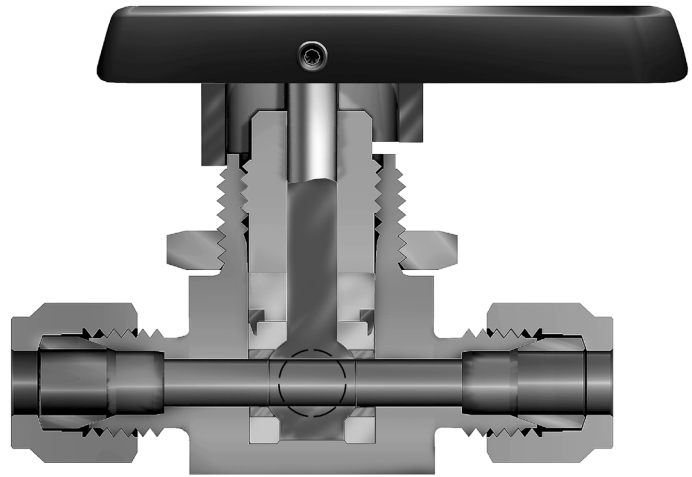

Detail of Seat/Packing
U.S. Patent No. 5,730,420

MB Series Ball Valves

2-Way In-Line

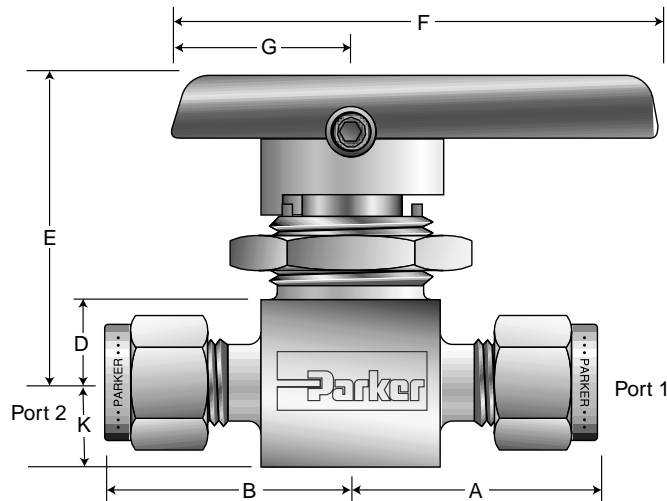

H - Maximum Panel Thickness
I - Panel Hole Diameter
J - Body Width

Model shown: 4A-MB6LPFA-SSP

2-Way In-Line Dimensions, Flow Data

Port Size	Basic Part #	Flow Data				End Connections		Dimensions inches (mm)									
		Orifice inch	Orifice mm	C_v	$x_T \ddagger$	Port 1	Port 2	A †	B †	D	E	F	G	H	I	J	K
1Z	- MB2L	0.052	1.3	0.03	0.46	1/16" CPI™		0.84	0.84	0.34	1.31	1.88	0.75	0.25	0.58	0.58	0.28
1A		1/16" A-LOK®	(21.3)	(21.3)													
2Z		1/8" CPI™	1.00	1.00													
2A		1/8" A-LOK®	(25.4)	(25.4)													
M3Z		3mm CPI™	1.00	1.00													
M3A	3mm A-LOK®	(25.4)	(25.4)														
2F	- MB4L	0.125	3.2	0.44	0.34	1/8" Female NPT		0.81	0.81	0.34	1.31	1.88	0.75	0.25	0.58	0.58	0.28
4Z						1/4" CPI™	1.12	1.12									
4A						1/4" A-LOK®	(28.5)	(28.5)									
4V						1/4" VacuSeal	1.06	1.06									
4Q						1/4" UltraSeal	0.88	0.88									
							(22.4)	(22.4)									
M6Z						6mm CPI™	1.12	1.12									
M6A	6mm A-LOK®	(28.5)	(28.5)														
2Z	- MB6L	0.093	2.4	0.18	0.55	1/8" CPI™		1.09	1.09	0.44	1.56	2.37	0.88	0.25	0.77	0.80	0.38
2A						1/8" A-LOK®	(27.7)	(27.7)									
2F						1/8" Female NPT	1.00	1.00									
4M						1/4" Male NPT	1.00	1.00									
							(25.4)	(25.4)									
4Z						1/4" CPI™	1.19	1.19									
4A						1/4" A-LOK®	(30.2)	(30.2)									
4F						1/4" Female NPT	1.03	1.03									
4KF						1/4" Female BSP/ISO Tapered	1.03	1.03									
							(26.2)	(26.2)									
4M4Z						1/4" Male NPT	1.00	1.19									
4M4A						1/4" Male NPT	1/4" A-LOK®	(25.4)	(30.2)								
6Z						3/8" CPI™	1.31	1.31									
6A						3/8" A-LOK®	(33.3)	(33.3)									
M6Z						6mm CPI™	1.19	1.19									
M6A	6mm A-LOK®	(30.2)	(30.2)														
M8Z	8mm CPI™	1.22	1.22														
M8A	8mm A-LOK®	(31.0)	(31.0)														

† For CPI™ and A-LOK®, dimensions are measured with nuts in the finger tight position.

‡ Tested in accordance with ISA S75.02. Gas flow will be choked when $P_1 - P_2 / P_1 = x_T$.

MB Series Ball Valves

2-Way Angle

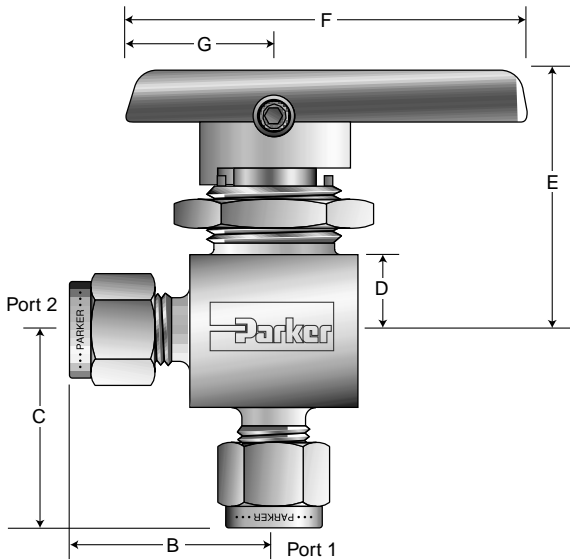

Model shown: 4A-MB6APFA-SSP

3-Way

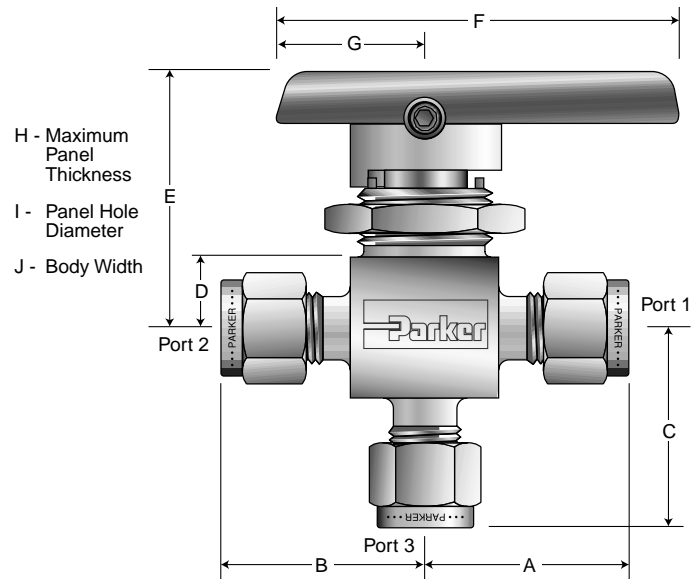

Model shown: 4A-MB6XPFA-SSP

2-Way Angle and 3-Way Dimensions, Flow Data

Port Size	Basic Part #	Flow Data				End Connections			Dimensions inches (mm)									
		Orifice inch	Orifice mm	C_v	$x_T \ddagger$	Port 1	Port 2	Port 3*	A†	B†	C†	D	E	F	G	H	I	J
1Z		0.052	1.3	0.02	0.58	1/16" CPI™			0.84	0.84	0.81							
1A						1/16" A-LOK®			(21.3)	(21.3)	(20.6)							
2Z	- MB2A	0.093	2.4	0.18	0.48	1/8" CPI™			1.00	1.00	0.97	0.34	1.31	1.88	0.75	0.25	0.58	0.58
2A	- MB2X					1/8" A-LOK®			(25.4)	(25.4)	(24.6)							
M3Z		0.086	2.2	0.15	0.47	3mm CPI™			1.00	1.00	0.97							
M3A						3mm A-LOK®			(25.4)	(25.4)	(24.6)							
2F						1/8" Female NPT			0.81	0.81	0.81							
4Z						1/4" CPI™			(28.4)	(28.4)	(28.4)							
4A	- MB4A	0.125	3.2	0.34	0.45	1/4" A-LOK®			1.06	1.06	1.09	0.34	1.31	1.88	0.75	0.25	0.58	0.58
4V	- MB4X					1/4" VacuSeal			(26.9)	(26.9)	(27.7)							
M6Z						6mm CPI™			1.12	1.12	1.12							
M6A						6mm A-LOK®			(28.4)	(28.4)	(28.4)							
4Z						1/4" CPI™			1.19	1.19	1.15							
4A						1/4" A-LOK®			(30.2)	(30.2)	(29.2)							
4F						1/4" Female NPT			1.03	1.03	1.03							
4KF						1/4" Female BSP/ISO Tapered			(26.2)	(26.2)	(26.2)							
4Z4Z4M	- MB6A	0.187	4.7	0.70	0.58	1/4" CPI™	1/4" CPI™	1/4" Male NPT	1.19	1.19	1.03	0.44	1.56	2.37	0.88	0.25	0.77	0.80
4A4A4M	- MB6X					1/4" A-LOK®	1/4" A-LOK®	1/4" Male NPT	(30.2)	(30.2)	(26.2)							
6Z						3/8" CPI™			1.31	1.31	1.23							
6A						3/8" A-LOK®			(33.3)	(33.3)	(31.2)							
M6Z						6mm CPI™			1.19	1.19	1.15							
M6A						6mm A-LOK®			(30.2)	(30.2)	(29.2)							
M8Z						8mm CPI™			1.22	1.22	1.18							
M8A						8mm A-LOK®			(31.0)	(31.0)	(30.0)							

* Not applicable for the 2-Way Angle pattern.

† For CPI™ and A-LOK®, dimensions are measured with nuts in the finger tight position.

‡ Tested in accordance with ISA S75.02. Gas flow will be choked when $P_1 - P_2 / P_1 = x_T$.

MB Series Ball Valves

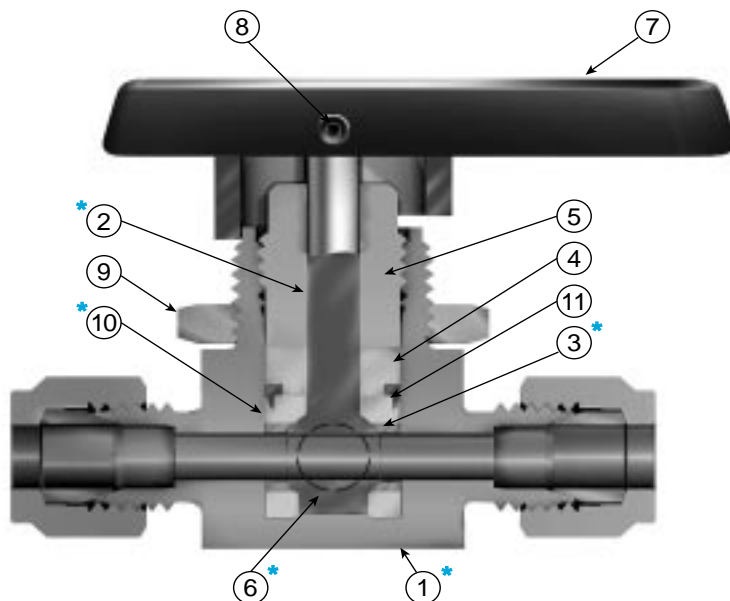

Materials of Construction

Item #	Part Description	Stainless Steel Valve	Brass Valve
*1	Body	ASTM A 276 TYPE 316	ASTM B 16 Alloy C36000
*2	Stem	ASTM A 276 TYPE 316	
*3	Hollow Insert	316 Stainless Steel	
4	Packing Washer	PEEK (Polyetheretherketone)	
5	Packing Nut	ASTM A 479 Type 316	ASTM B 16 Alloy C36000
*6	Solid Insert	316 Stainless Steel	
7	Handle	Nylon 6/6	
8	Set Screw	Stainless Steel	
9	Panel Nut	316 Stainless Steel	
*10	Seat/Packing	Perfluoroalkoxy (PFA)	
11	Packing Ring	ASTM A 479 Type 316	

* Wetted Parts
Lubrication: Perfluorinated polyether

Available Options

Lock-Out Devices
Colored Handles
Stainless Steel Handles
Oval Handles
Upstream or Downstream
(default) Vented Valves
Oxygen Cleaning
Special Cleaning
Pneumatic and Electric Actuation
(see Catalogs 4123-PA and 4123-EA for additional actuator information)

Pressure vs. Temperature

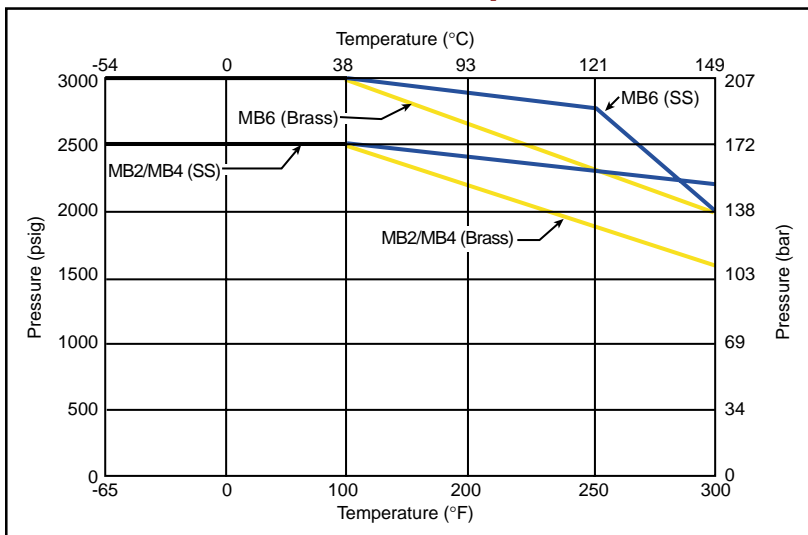

NOTE: To determine MPa, multiply bar by 0.1

MB Series Ball Valves

How to Order 2-Way In-Line Patterns

The correct part number is easily derived by following the circled number sequence.

Example: 2Z - MB2LPFA - SSP
 ①②* ④ ⑤ ⑥

Describes a MB Series, 2-way, in-line pattern ball valve with 1/8" CPI™ compression end connections for ports 1 and 2, PFA seat and packing, stainless steel body construction, and a panel mounting nut.

① Port 1	② Port 2	④ Valve Series	⑤ Seat Material	⑥ Body Material
1Z - 1/16" CPI™		MB2L	PFA - Perfluoroalkoxy	SSP - Stainless Steel (Stainless Steel with Panel Nut) BP - Brass (Brass with Panel Nut)
1A - 1/16" A-LOK®				
2Z - 1/8" CPI™				
2A - 1/8" A-LOK®				
M3Z - 3mm CPI™				
M3A - 3mm A-LOK®				
2F - 1/8" Female NPT		MB4L		
4Z - 1/4" CPI™				
4A - 1/4" A-LOK®				
4V - 1/4" VacuSeal				
4Q - 1/4" UltraSeal				
M6Z - 6mm CPI™				
M6A - 6mm A-LOK®		MB6L		
2Z - 1/8" CPI™				
2A - 1/8" A-LOK®				
2F - 1/8" Female NPT				
4Z - 1/4" CPI™				
4A - 1/4" A-LOK®				
4F - 1/4" Female NPT				
4KF - 1/4" Female BSP/ISO Tapered				
4M - 1/4" Male NPT				
6Z - 3/8" CPI™				
6A - 3/8" A-LOK®				
M6Z - 6mm CPI™				
M6A - 6mm A-LOK®				
M8Z - 8mm CPI™				
M8A - 8mm A-LOK®				

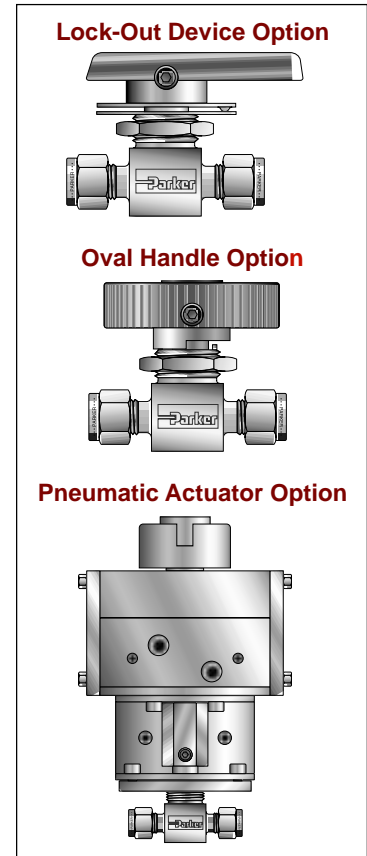

* Valves with identical port connections for port 1 and port 2 require only one designator.

How to Order Options (2-way, Angle, and 3-way)

Lock-Out Devices – Add the suffix **-LD** to the end of the part number to order directly on the valve. **Example:** 2F-MB4LPFA-SSP-LD. For field installation, simply substitute the correct valve series number in the following nomenclature: **LD**-valve series. **Example:** LD-MB6L

Colored Handles – Add the designator corresponding to the correct handle as a suffix to the part number: **W** - white, **B** - blue, **G** - green, **R** - red, **Y** - yellow. **Example:** 4Z-MB6LPFA-SSP-G

Stainless Steel Handles – Add the suffix **-ST** to the part number. **Example:** 4F-MB6LPFA-SSP-ST

Oval Handles – Add the suffix **-S** to the part number. **Example:** 6Z-MB6APFA-SSP-S. If requesting a colored oval handle, add the suffix **-S**-color designator. **Example:** 6Z-MB6APFA-SSP-S-W

Upstream or Downstream (default) Vented Valves – Add the designator **V** after the **MB** in the part number for the default downstream vent. **Example:** 2Z-MBV2XPFA-SSP. For upstream vents, add the designator **VU** after the **MB** in the part number.

Example: 2Z-MBVU2XPFA-SSP

Oxygen Cleaning – Add the suffix **-C3** to the end of the part number to receive valves cleaned and assembled for oxygen service in accordance with Parker Specification ES8003. **Example:** 4A-MB4LPFA-SSP-C3

Special Cleaning – All face seal ended valves are cleaned in accordance with Parker Specification ES8001. This is an available option for all valves by adding the suffix **-C1** to the end of the part number. **Example:** 4V-MB4XPFA-SSP-C1

Pneumatic Actuators – For detailed actuator information, refer to Catalog 4123-PA. For factory assembly, add the actuator part number as the suffix to the valve part number. **Example:** 4A-MB4LPFA-SSP-61AC-2. For field installation, specify the actuator desired. **Example:** 61AC-2. The appropriate mounting hardware may be obtained by adding the valve series and actuator size to the prefix **MK**. **Example:** MK-MB4L-61

Electric Actuators – For detailed actuator information, refer to Catalog 4123-EA. For factory assembly, add the actuator part number as the suffix to the valve part number. **Example:** M6A-MB6XPFA-SSP-71C. For field installation, specify the actuator desired. **Example:** 71C. The appropriate mounting hardware may be obtained by adding the valve series and actuator series to the prefix **MK**. **Example:** MK-MB6X-70

How to Order Angle and 3-Way Patterns

The correct part number is easily derived by following the circled number sequence.

Example: 4A4A4M - MB6XPFA - BP
 ① ② ③ * ④ ⑤ ⑥

Describes a MB Series, 3-way pattern ball valve with 1/4" A-LOK® compression end connections for ports 1 and 2, male NPT end connection for port 3, PFA seat and packing, brass body construction, and a panel mounting nut.

① Port 1	② Port 2	③ Port 3	④ Valve Series	⑤ Seat Material	⑥ Body Material	
1Z - 1/16" CPI™			MB2A MB2X	PFA - Perfluoroalkoxy	SSP - Stainless Steel (Stainless Steel with Stainless Steel Panel Nut)	
1A - 1/16" A-LOK®						
2Z - 1/8" CPI™						
2A - 1/8" A-LOK®						
M3Z - 3mm CPI™						
M3A - 3mm A-LOK®						
2F - 1/8" Female NPT			MB4A MB4X		PFA - Perfluoroalkoxy	BP - Brass (Brass with Stainless Steel Panel Nut)
4Z - 1/4" CPI™						
4A - 1/4" A-LOK®						
4V - 1/4" VacuSeal						
M6Z - 6mm CPI™						
M6A - 6mm A-LOK®						
4Z - 1/4" CPI™			MB6A MB6X	PFA - Perfluoroalkoxy	BP - Brass (Brass with Stainless Steel Panel Nut)	
4A - 1/4" A-LOK®						
4F - 1/4" Female NPT						
4KF - 1/4" Female BSP/ISO Tapered						
4M - 1/4" Male NPT						
6Z - 3/8" CPI™						
6A - 3/8" A-LOK®						
M6Z - 6mm CPI™						
M6A - 6mm A-LOK®						
M8Z - 8mm CPI™						
M8A - 8mm A-LOK®						

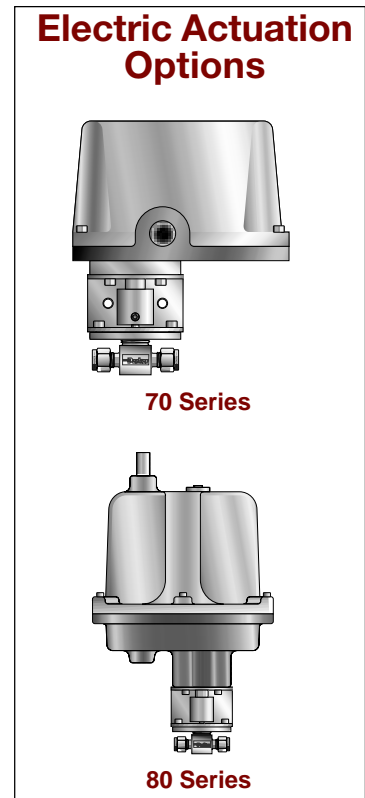

* Valves with identical port connections for port 1, 2, and 3 require only one designator. Port 3 is not applicable for the 2-way angle pattern.

! WARNING

FAILURE, IMPROPER SELECTION OR IMPROPER USE OF THE PRODUCTS AND/OR SYSTEMS DESCRIBED HEREIN OR RELATED ITEMS CAN CAUSE DEATH, PERSONAL INJURY AND PROPERTY DAMAGE.

This document and other information from Parker Hannifin Corporation, its subsidiaries and authorized distributors provide product and/or system options for further investigation by users having technical expertise. It is important that you analyze all aspects of your application and review the information concerning the product or system in the current product catalog. Due to the variety of operating conditions and applications for these products or systems, the user, through its own analysis and testing, is solely responsible for making the final selection of the products and systems and assuring that all performance, safety and warning requirements of the application are met.

The products described herein, including without limitation, product features, specifications, designs, availability and pricing, are subject to change by Parker Hannifin Corporation and its subsidiaries at any time without notice.

Offer of Sale

The items described in this document are hereby offered for sale by Parker Hannifin Corporation, its subsidiaries or its authorized distributors. This offer and its acceptance are governed by the provisions stated in the "Offer of Sale" located in Catalog 4110-U Needle Valves (U Series).



Catalog 4121-MB, 30M, 06/01

Parker Hannifin Corporation
Instrumentation Valve Division
2651 Alabama Highway 21 North
Jacksonville, AL 36265-9681
USA
Phone: (256) 435-2130
Fax: (256) 435-7718
www.parker.com/IVD



Parker Hannifin plc
Instrumentation Products Division
Riverside Road
Pottington Business Park
Barnstaple, Devon EX31 1NP
England
Phone: +44 (0) 1271 313131
Fax: +44 (0) 1271 373636
Email: ipd@parker.com
www.parker.com/IPD

